

INSOMNIAC SmartLock® O

SML-O-100-01R

P/N SML-O-100-01R
Revision 1.1
Date Code: 3-31-2026

Patented Product Name	Patent Number/s
INSOMNIAC SmartLock®	U.S. Pat. No. 12,146,345 U.S. Pat. No. 12,385,289 and patents pending

Contents

INSTALLATION SPECIFICATIONS	2
WARNINGS.....	2
OVERVIEW	3
HOW TO CONTACT US.....	3
PACKAGE CONTENTS	4
TOOLS REQUIRED FOR INSTALLATION	4
MOUNTING SMARTLOCK O	9
WIRELESS COMMUNICATIONS	11
TESTING & TROUBLESHOOTING	12
MAINTENANCE	14
NOTICES and DISCLAIMERS.....	15

INSTALLATION MANUAL

INSOMNIAC SmartLock® O

INSTALLATION SPECIFICATIONS

ITEM	DESCRIPTION	FEATURES
1	ENCLOSURE	INDOOR, OUTDOOR, ABS PLASTIC, STAINLESS STEEL
2	COMMUNICATIONS	WIRELESS (2.4 GHz)
3	COMMUNICATIONS RANGE	60 METERS / 200 FEET - ACROSS 16 METERS / 55 FEET - Laterally
4	SECURE COMMUNICATIONS	YES
5	BATTERY VOLTAGE RANGE	12v - 12.5v
6	BATTERY TYPE	AA ALKALINE
7	BATTERY QUANTITY	8
8	BATTERY CAPACITY	25,000 mAh
9	BATTERY LIFE EXPECTANCY	6+ YEARS IN CLIMATE CONTROLLED FACILITIES
10	OPERATING TEMPERATURE RANGE	-20 °F - 140 °F
11	COMPLIANCE	FCC, CE
12	INGRESS PROTECTION RATING	IP56
13	COMPATIBLE DOOR STYLE	SQUARE CORRUGATION & FLAT DOOR
14	COMPATIBLE LATCH STYLE	STANDARD 4-BOLT PATTERN (CHATEAU / JANUS)

IMPORTANT

- All installations must conform to local building and electrical codes and shall be in accordance with the **National Electric Code, ANSI/NFPA 70**.
- When discrepancies exist between local codes and this manual, local code takes precedence.
- Follow recommended UL installation standards. Find the standards catalog here: [Standards Catalog | UL Solutions](#)
- Improper installation or usage may affect any otherwise eligible hardware protection coverage.



WARNINGS

Disregarding any warning in this document may void any hardware coverage in place at the time of installation.

INSTALLATION MANUAL

INSOMNIAC SmartLock® O

OVERVIEW

The OpenTech Alliance, Inc. **INSOMNIAC SmartLock®** (O model) is a wireless smart unit hasp designed to manage access to each storage unit, show timeline of access, and overlock access to delinquent tenants. Each SmartLock is assigned to a specific unit within a facility; this allows for storage unit specific access monitoring and reporting.

SmartLock communicates with the **OpenTech IoE Control Center**, a centrally managed, **internet-accessible** platform that serves as the system’s source for access permissions, configuration data, and reporting. In the event of an internet outage, the SmartLock will continue to function by caching access codes and events locally. These cached access codes will allow **uninterrupted access to the unit**. During this time, however, configuration updates cannot be applied until the IoE Control Center connection is reestablished.

Each SmartLock contains a main PCB, a battery pack with 8 AA batteries, and overlocking capable hasp (a locking mechanism that allows facility managers to restrict access to a unit, for example when a tenant is delinquent on payments). The SmartLock is intended for **indoor or outdoor** use. The SmartLock can integrate with and support broader security functions such as access control, incident response and prevention, and event-based alerts. Final control logic and rules for operation are always managed and configured through the IoE Control Center.

Also refer to related guides and manuals in OpenTech’s [Resource Library](#) and [Help Center](#).

<https://opentechalliance.com/resource-library/>

HOW TO CONTACT US

OpenTech Alliance, Inc. Customer Onboarding and Technical Support

(US-based, available 24/7)

Phone (US)

602-773-1700

For installation help, select Onboarding
For post-installation help, Technical Support

Phone (Non-US)

Click the [Website Support link](#) to find your contact details

Website

<https://opentechalliance.com/support/>

Email

support@opentechalliance.com



Looking for an authorized installer?

Click the link or QR code to find Authorized Dealers in your area who sell and service OpenTech’s INSOMNIAC® self storage solutions

<https://opentechalliance.com/dealers/>

INSTALLATION MANUAL

INSOMNIAC SmartLock® O

PACKAGE CONTENTS

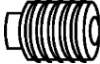
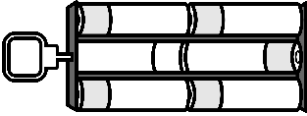
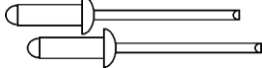
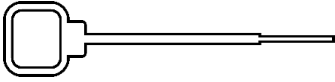
INSOMNIAC SmartLock O		(1) Set Screw	
Battery Pack with (8) AA Alkaline Batteries		(6) 1/4" Pop Rivets	
Battery Pack Removal Key			

TOOLS REQUIRED FOR INSTALLATION

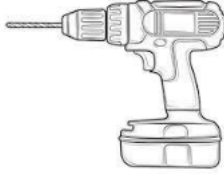
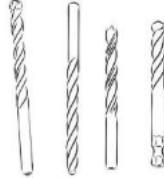
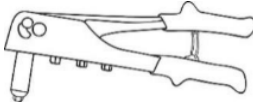
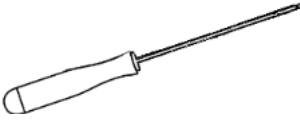
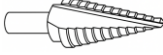
NON-IMPACT Driver Drill		17/64" Drill Bits *Carbide Drill Bits or HSS (High-Speed Steel) Bits Recommended*	
Pop Rivet Tool *Powered Rivet Tool Recommended*		5/64" Ball End Screwdriver	
#4 Step Drill Bit			



WARNING! Do not use an impact driver. Use a **standard driver drill** to avoid damaging the device and/or mounting hardware.

INSTALLATION RECOMMENDATION

A successful SmartLock deployment depends not only on correct physical installation but also on the order in which devices are brought online. Because SmartLocks communicate over a self-healing Wirepas mesh, the network needs time to absorb each new device, assign a routing path, and propagate configuration data (including tenant access codes) from the IoE Control Center. Following the sequence below will prevent avoidable connectivity issues, false alarms, and delayed configuration updates during installation.



IMPORTANT – Do not power on all SmartLocks in an area at the same time. When dozens of devices boot simultaneously, the mesh is flooded with startup traffic, join requests, and device-state alarms. This can bog down the network, delay configuration propagation, and cause commands that typically take 5 seconds to activate, to take up to 45 minutes. If you wish to test the functionality of the locks, power on 10-15 devices and test, **then power off them off** and install them.

Recommended Workflow

PHASE 1 - Receiving and Inspection

Complete this phase as soon as the shipment arrives, before installation day if possible.

Step 1.1 - Inspect the outer packaging.

- Look for crushed corners, punctures, water staining, or signs that boxes were dropped.
- Photograph any visible damage to the outer packaging before opening. These photos will be required if a damage claim needs to be filed.

Step 1.2 - Verify quantities against the packing list.

- Confirm the number of SmartLocks, battery packs, removal keys, rivets, set screws, and (for SmartLock S) mounting templates matches what was ordered.
- Note any shortages immediately and contact OpenTech Onboarding at 602.773.1700.

Step 1.3 - Inspect each SmartLock for shipping damage.

Before doing anything else with a SmartLock, check for:

- Cracks, chips, or stress marks in the ABS plastic enclosure.
- Bent, gouged, or misaligned stainless steel hasp or slider.
- Damage to the touchpad surface.
- Dirt, moisture, or corrosion inside the battery compartment.



WARNING! Do not install a SmartLock that shows signs of damage. A damaged enclosure can compromise the IP56 rating, and damaged internal components may fail after installation. Set any damaged units aside and **contact Onboarding for replacement** before proceeding.

Step 1.4 - Inspect each battery pack.



IMPORTANT - Batteries are sometimes installed backwards from the factory or during repackaging. Before installing any battery pack into a SmartLock, verify that every AA battery is oriented correctly.

- Check every row of batteries against the orientation labels printed on the battery pack.
- Confirm a silver/copper contact is visible at each end of every battery row, and that each battery is touching the silver connectors or adjacent batteries.

INSTALLATION MANUAL

INSOMNIAC SmartLock® O

- Look for corrosion, leakage, or swollen cells. Replace any compromised batteries before proceeding. If a battery is reversed, carefully remove it, reorient it to match the label, and reinstall it. A reversed battery will cause the SmartLock to report incorrect battery percentages in the IoE Control Center, fail to power on, or - in worst cases - damage the battery pack.

Step 1.5 - Stage inspected units.

- Keep battery packs separated from SmartLocks during staging. Do not insert battery packs at this stage.
- Group SmartLocks by the building or hallway where they will be installed to simplify the batch workflow in Phase 4.

PHASE 2 - Pre-Installation Network Check

Step 2.1 - Confirm OpenNet is online.

- Verify that the OpenNet Edge Router covering the installation area appears Online.
- Verify that every OpenNet Access Point covering the installation area appears Online.

Step 2.2 - Do not proceed if any network device is offline.

The mesh infrastructure must be healthy before SmartLocks are added to it. Resolve any offline OpenNet device before moving to Phase 3. Contact OpenTech Onboarding if assistance is needed.

PHASE 3 - Mounting (Battery Packs Out)

Step 3.1 - Keep the battery pack removed.

Mount every SmartLock in an area with the battery pack not installed. A mounted, unpowered SmartLock allows you to physically install a large number of locks without energizing any of them.

Step 3.2 - Follow the mounting procedure for your SmartLock model.

Refer to the MOUNTING SMARTLOCK O section later in this manual for the model-specific mounting steps. Complete the full procedure - drilling, riveting, alignment checks, set screw - with no battery pack installed.

Step 3.3 - Verify slider movement before leaving each lock.

Manually cycle the slider between locked and unlocked positions. If movement is rough or obstructed, unmount and readjust now - it is much harder to correct alignment after the lock is powered on and assigned in the IoE Control Center.

Step 3.4 - Track which locks are mounted.

Maintain a list or facility map of mounted-but-unpowered locks with the last 4 of their UID and the unit. You will work through this list in Phase 4 in defined batches. You will also need to provide this to OpenTech Alliance's Onboarding team for pairing the SmartLock to the unit.

PHASE 4 - Batch Power-On

Step 4.1 - Select a batch of approximately 27 SmartLocks.

- For most facilities, 27 locks per batch is the recommended maximum.
- For smaller facilities with a single OpenNet Access Point, consider smaller batches (10-15).

INSTALLATION MANUAL

INSOMNIAC SmartLock[®] O

Step 4.2 - Install the battery pack in each lock in the batch.

- Align the battery pack with the interior of the enclosure.
- Gently push the battery pack into place until it clicks and the LED light sequence activates.
- Confirm the boot sequence: **RED**, **GREEN**, **BLUE**.

Step 4.3 - Observe the initial LED state.

After boot, each SmartLock will display:

- **WHITE** - Finding Network (normal immediately after boot)
- **BLINKING RED** - Disconnected (normal briefly; should transition within a few minutes)

Do not attempt to test the lock yet. Move on to the next lock in the batch.

Step 4.4 - Finish powering on every lock in the batch before proceeding.

Do not begin Phase 5 until all ~27 locks in the current batch have had their battery packs installed.

PHASE 5 - Settling Period

This phase requires patience, not action. Allow the mesh and the IoE Control Center to do their work.

Step 5.1 - Wait for each lock to reach **MAGENTA**.

- Allow up to 5 minutes per device to reach a stable network connection.
- A SmartLock is Connected to Network when its LED flashes **MAGENTA**.
- It is normal during this window to see devices briefly reboot, go unresponsive, or cycle through states as configuration is applied.

Step 5.2 - Wait an additional 5-10 minutes for configuration propagation.

Once the final lock in the batch reaches **MAGENTA**, wait 5-10 minutes before testing. During this window the IoE Control Center is pushing configuration data to each lock, including:

- Tenant access codes
- Overlock status
- Schedule and permission data
- Facility-level configuration

Step 5.3 - Understand that newly issued codes take time to reach the lock.

Access codes created or modified in the IoE Control Center during the settling period may not be immediately usable at the lock. This is normal - the code will become active once propagation completes. To speed up the process, a member of OpenTech Alliance's Onboarding team can regenerate the codes manually.

PHASE 6 - Spot-Check Testing

Do not test every lock individually. Spot-checking a sample is sufficient to catch batch-level problems.

Step 6.1 - Randomly select 3-5 locks from the batch.

Choose locks from different parts of the batch's physical area - near and far from the nearest OpenNet Access Point, if possible.

Step 6.2 - Verify Online status.

- In the IoE Control Center, confirm each selected lock appears Online.
- Confirm the reported battery percentage is reasonable (a reversed battery from Phase 1 will often surface here as an implausible reading).

INSTALLATION MANUAL

INSOMNIAC SmartLock® O

Step 6.3 – Verify physical hasp and slider operation.

- Manually cycle the SmartLock slider between locked and unlocked positions.
- Confirm the hook smoothly engages and disengages the existing unit hasp's slider flange.
- Confirm three **GREEN** flashes (Successful Lock) when the SmartLock seats into the locked position. This is the only LED-based confirmation of a healthy lock cycle on Model O.
- If movement is rough, the lock is misaligned. Note the unit and unmount/readjust later – do not force the slider.

Step 6.4 - Decide whether to continue.

- If all sampled locks pass: Proceed to Phase 4 with the next batch.
- If one lock fails: Troubleshoot that individual lock but continue to the next batch.
- If two or more sampled locks fail: Pause. A batch-wide problem is likely (network overload, OpenNet issue, or reversed batteries missed in Phase 1). Investigate before powering on any additional batches.

PHASE 7 - Final Facility Verification

Complete this phase only after every batch has been installed and spot-checked.

Step 7.1 - Review the full device list in the IoE Control Center.

Confirm that every SmartLock assigned to the facility reports Online.

Step 7.2 - Investigate any stragglers.

For any lock showing Offline, Finding Network, or Disconnected more than 30 minutes after its batch was powered on:

- Check the LED state at the device.
- Verify the battery pack is fully seated and batteries are correctly oriented.
- Confirm the lock is within range of at least two other active SmartLocks or an OpenNet Access Point.
- **Power-cycle the lock by removing the battery pack and reinstalling it after 30 seconds.**

Why This Matters

- **Mesh stability.** The Wirepas mesh is designed to self-heal and self-balance, but it does so most reliably when devices join gradually. Staggered joins allow each new lock to find an efficient route to the sink without competing with dozens of other new devices.
- **Fewer false alarms.** A SmartLock that cannot immediately reach the network will report disconnection events and alarming events. Powering on hundreds of locks at once can generate a flood of these alarms in the IoE Control Center, making it difficult to distinguish real issues from installation noise.
- **Reliable overlock on day one.** Configuration data – unit pairing, overlock status, schedules, and facility settings – is pushed from the IoE Control Center over the mesh. If locks are still negotiating their place on the network, that configuration is delayed and a delinquent unit may not overlock when expected. Staged installation gives the system time to fully configure each device before it is put into service.

INSTALLATION MANUAL

INSOMNIAC SmartLock® O

MOUNTING SMARTLOCK O

For assistance **during installation** please contact our customer onboarding team.
Phone: 602.773.1700 | Email: ioeonboarding@opentechalliance.com



Remove the battery pack during installation. Wait until every pop rivet is secured to reinstate the battery pack. Installing the SmartLock while the battery pack is installed could result in damage to the battery pack and or SmartLock. This will not be covered under OpenTech's protection plan.

Prepare the SmartLock and Hasp by placing the SmartLock next to the existing hasp, placing the hook over the existing hasp's slider flange (the flat protruding tab on the existing hasp that slides in and out when the unit is locked and unlocked).

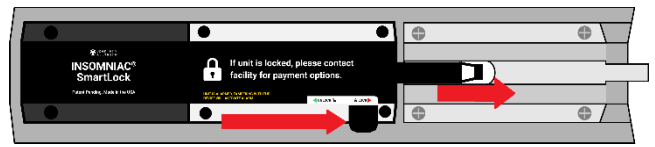

Figure 1

Fully extend the hasp on unit door to the locked position.

This will properly position the latch to function with any lock style suitable for the hasp, then **fully extend the SmartLock** slider handle to locked position. (Fig. 1)



Both the existing hasp and the SmartLock slider must be held in the fully extended locked position simultaneously while drilling the first rivet hole. This step is significantly easier with two people.

Continue to hold the SmartLock and hasp in their **extended locked position** and drill out the first pop rivet hole, then secure the **first pop rivet**. (Fig. 2)

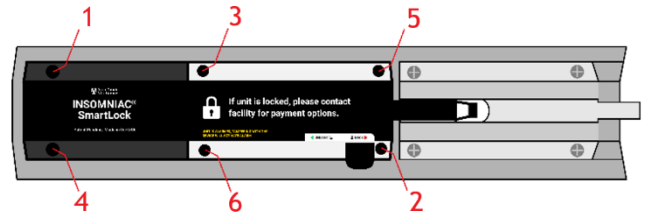

Figure 2



Use the first rivet as a pivot point to align the SmartLock horizontally. Match the angle of the grooves in the corrugated door, ensuring the SmartLock is not crooked nor misaligned.



Misaligning the SmartLock within the corrugation of the unit door will result in damage to the SmartLock and this will not be covered under any hardware protection plan. Consult an OpenTech Specialist during installation if the alignment or fitment is incorrect.

INSTALLATION MANUAL

INSOMNIAC SmartLock® O

Drill the next pop rivet hole, choosing to go in a **star pattern** to ensure even compression on the SmartLock. Then **secure the second pop rivet** into the SmartLock. (Fig. 3)

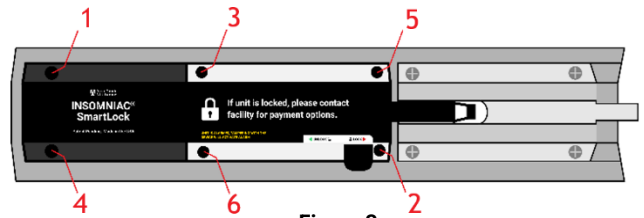

Figure 3



Take this time to verify the SmartLock & Hasp movement by unlocking the SmartLock and sliding the SmartLock handle into the unlocked position. If movement is rough or not possible this is the time to unmount and or readjust as needed.

Install the Remaining Pop Rivets by drilling out remaining mounting holes then securing each pop rivet into the SmartLock. Ensure you continue to follow the **star pattern** for even compression onto the SmartLock. (Fig. 4)

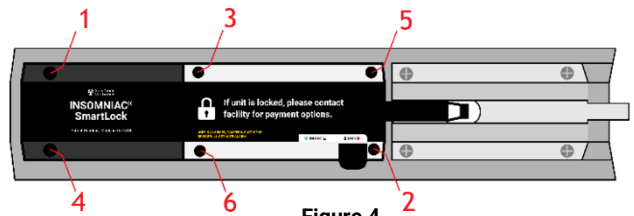

Figure 4

Secure the Hook Set Screw attaching the SmartLock to the existing unit hasp. If needed, you may need to create or bore the hole in the hasp to ensure a proper fit. (Fig. 5)

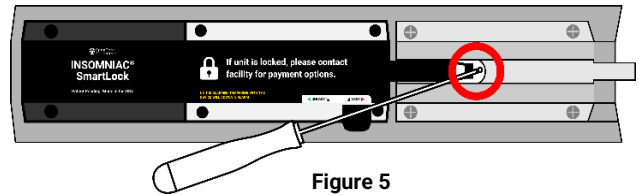

Figure 5



WARNING! The hook set screw should not extend past the hasp connector.

WIRELESS COMMUNICATIONS

SmartLocks use Wirepas mesh protocols to create a reliable and energy-efficient wireless network. Each SmartLock is capable of communicating not only with an Access Point but also with other nearby SmartLocks and other OpenTech sensors. By passing messages between devices, the network is able to cover a wide area while keeping individual transmission distances short.

Each SmartLock has an effective range of approximately **60 meters (200 feet) across** and **16 meters (55 feet) laterally** when there is a clear line of sight. The Access Points provide a much wider communication range, reaching up to 200 meters (650 feet) in open conditions. In addition, OpenTech Alliance provides other sensor products like INSOMNIAC® SmartMotion™, which adds to this mesh network of devices. Together, these ranges allow SmartLocks to connect to each other and to Access Points without requiring high transmit power, which helps preserve battery life.

At the center of the system is the OpenNet Access Point, which contains the Wirepas sink node. The sink serves as the collection point for all wireless traffic coming from the sensors. Once data reaches the sink, it is forwarded through the OpenNet Access Point into the OpenNet network, where it can be processed by the OpenNet Edge Router and made available to applications such as the IoE Control Center, Manager Genie, and Storage Genie.

Because the network is built on a self-healing mesh, each SmartLock automatically finds the most efficient path to reach the sink. If one SmartLock or Access Point becomes unavailable, nearby devices will reroute traffic through alternative nodes. This redundancy ensures reliability across the facility.

In practice, SmartLocks should be positioned so they are within range of at least two other active SmartLocks or an Access Point. When installed in this way, the mesh continuously balances itself, maintaining connectivity and ensuring that access to the unit is persistent.

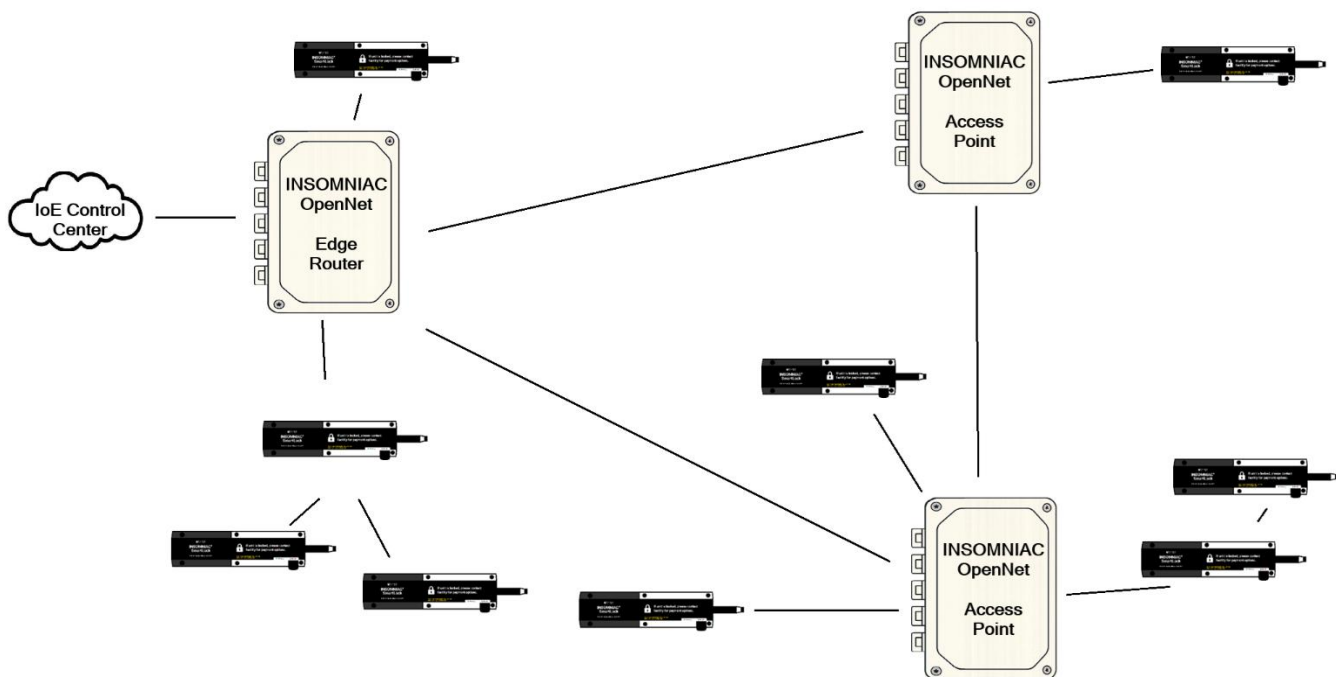

Figure 6

TESTING & TROUBLESHOOTING

INSOMNIAC SmartLock O

Test the SmartLock by powering up the device with a fresh battery pack. There is an LED indicator as shown (Figure 7) that flashes (**RED**, **GREEN**, **BLUE**) on boot. Once the device is powered on it will flash (**RED**) until it has found a stable connection to the network. This is normal.

Once the SmartLock's connection has been established with the network it will flash (**MAGENTA**). The device will then confirm its configuration and update its configuration; you may see the device become unresponsive or reboot during this period. Allow up to 5 minutes for the device to fully establish its connection and update its configuration.

The LED Indicator is the best indication of the current state of the SmartLock. Please refer to the table and diagram below.

ITEM	STATE	LED INDICATION
1	BOOT	RED , GREEN , BLUE
2	FINDING NETWORK	WHITE
3	DISCONNECTED	BLINKING - RED
4	CONNECTED TO NETWORK	MAGENTA
5	SUCCESSFUL LOCK	THREE GREEN
6	READY TO LOCK	BLINKING - YELLOW
7	PAIRING TO NETWORK	CYAN

To power cycle the SmartLock, remove the battery pack and reinstate the battery pack after 30 seconds, this will initiate another start up sequence (**RED**, **GREEN**, **BLUE**). Power cycling is useful if the SmartLock appears frozen or unresponsive. If the issue persists after one power cycle, contact support.

Once fully configured, the SmartLock will appear as 'Online' in the IoE Control Center.



The main PCB carries a Master ID Address called the UID. If this board is changed out, the new board's UID must be entered in IoE Control Center, replacing the previous board's address before the board will function.

INSTALLATION MANUAL

INSOMNIAC® SmartLock O

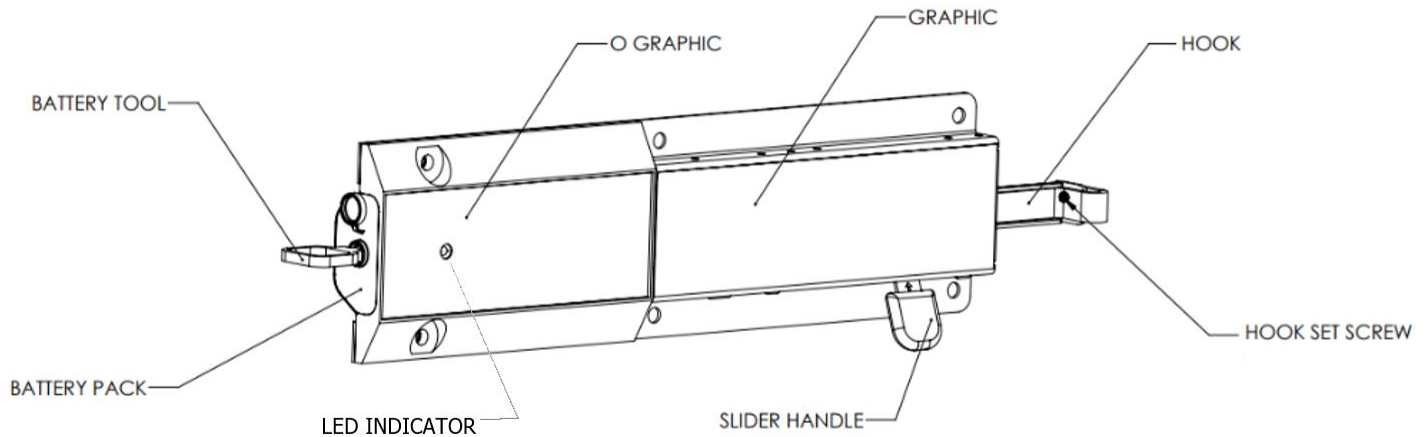

Figure 7

Battery Operation



WARNING! Proper handling of the battery and key is critical to avoid damage and ensure the SmartLock functions correctly.

Battery Installation

Verify that all batteries are correctly oriented to ensure that accurate battery life is displayed in the IoE Control Center.

1. Aligning the battery pack with the interior of the enclosure, ensuring it does not collide with any intrusions.
2. Gently push the battery pack into place until it clicks, and the LED light sequence activates.

Battery Removal

When removing the battery from a SmartLock, follow these steps carefully to ensure proper handling:

1. Ensure the removal key is inserted properly:
 - a) The key's tooth (end of the key) must face toward the storage unit (away from you).
2. Insert the key fully into the lock until the entire length of the key is inside.
3. Rotate the key 90 degrees clockwise, then gently pull to remove the battery pack

INSTALLATION MANUAL

INSOMNIAC® SmartLock O

Battery Integrity

The SmartLock battery pack is designed for straightforward use. If you experience issues such as the SmartLock does not power on or report an inaccurate battery percentage, check the following:

1. Verify Battery Alignment
 - a. Check the alignment of the batteries inside the battery pack.
 - b. Ensure each row of batteries is correctly oriented based on the labels indicating their proper placement.
2. Inspect the Battery Pack
 - a. Confirm that there is a silver/copper contact at each end of every battery row, enabling proper connection between batteries.
 - b. Ensure all batteries are contacting the silver connectors or adjacent batteries.
 - c. If any damage is present, a replacement battery pack is required.
3. Replace Batteries
 - a. Test the battery pack with fresh, fully charged batteries to rule out partially drained batteries causing inaccurate battery percentage readings.

Note: If issues persist after completing these steps, consider contacting support for further assistance.

MAINTENANCE

SmartLock O

Inspect and clean the enclosure and touchpad periodically to ensure superior performance over time.



- **Do not** use alcohol, harsh chemicals, abrasives, or petroleum-based products.
- **Do not** use a pressure washer.

Annually

1. Spray the SmartLock with a mild soapy water solution then wipe it with a soft cloth.
2. Verify integrity of mounting hardware and or solutions.

Batteries

Every six years replace the batteries, following this process:

1. Open the battery pack cap located on the interior side of the SmartLock.
2. Insert the battery key all the way into the battery compartment.
3. Rotate the battery key 90 degrees clockwise.
4. Pull the battery key out with the battery pack.
5. Rotate the battery key 90 degrees counterclockwise.
6. Remove battery key from battery pack, close the battery pack cap.
7. Replace double AA Alkaline batteries, making sure the orientation is correct.
8. Insert battery pack in the SmartLock with the battery pack cap facing the interior of the door.

NOTICES and DISCLAIMERS

FCC Part 15 Notice: The referenced equipment has been tested and found to comply with the limits for a Class B digital device, pursuant to Part 15 of the FCC Rules. These limits are designed to provide reasonable protection against harmful interference in a residential installation. This equipment can generate and radiate radio frequency energy and, if not installed and used in accordance with the instructions, may cause harmful interference to radio communications.

Our Patent(s): *The following products are protected by patent(s) in the U.S. and elsewhere for OpenTech Alliance, Inc. This website is provided to satisfy the virtual patent marking provisions of various jurisdictions including the virtual patent marking provisions of the America Invents Act and provide notice under 35 U.S.C. §287(a). The following list of products and patents may not be all-inclusive. For example, some products listed here may be covered by patents in the United States and elsewhere that are not listed, and other products not listed here may be protected by one or more patents in the United States and elsewhere. The following list of products may be covered by one or more of the following U.S. and foreign patents and patents pending.*

Patented Product Name	Patent Number
INSOMNIAC SmartLock®	U.S. Pat. No. 12,146,345 U.S. Pat. No. 12,385,289 and patents pending

Liability Disclaimer: While every effort has been made to ensure the accuracy of the information in this document, we assume no liability for any inaccuracies contained herein. We reserve the right to change the information contained herein at any time and without notice.