

INSOMNIAC® OpenNet™

OPN-ER-100WP

P/N OPN-ER-100WP
Revision 2.1
Date Code: 3-31-2026

Contents

INSTALLATION SPECIFICATIONS.....	2
WARNINGS	2
OVERVIEW	2
CONTACT US.....	3
PACKAGE CONTENTS	3
TOOLS & MATERIALS REQUIRED FOR INSTALLATION.....	4
Other Requirements	4
POWER OPTIONS	4
MOUNTING OPENNET	5
INSTALLATION RECOMMENDATIONS.....	6
MESH COMMUNICATIONS FOR SELF STORAGE	11
PORT CONFIGURATION.....	12
WIRELESS RANGE AND PLACEMENT	13
WIRELESS NETWORK WITH OPENTECH'S SMART DEVICES.....	14
NETWORK CONFIGURATION SCENARIOS	14
Tethering Configurations.....	17
TESTING AND TROUBLESHOOTING.....	19
LED Status Indicators	20
MAINTENANCE	22
NOTICES AND DISCLAIMERS.....	22

INSTALLATION SPECIFICATIONS

ITEM	DESCRIPTION	FEATURES	
1	ENCLOSURE	INDOOR, OUTDOOR	
2	COMMUNICATIONS	WIRELESS (2.4 GHz & 5 GHz)	
3	COMMUNICATIONS RANGE	200 METERS / 656 FEET	
4	SECURE COMMUNICATIONS	YES	
5	POWER SUPPLY	ETHERNET PoE+	
6	POE RATING	IEEE 802.3at 48~56V	
7	POWER CONSUMPTION	30W (MAX)	
8	OPERATING TEMPERATURE RANGE	-20 °F - 140 °F	
9	COMPLIANCE	FCC, CE	
10	INGRESS PROTECTION RATING	IP67	
11	WI-FI CHANNELS	IoT, GUEST, CORPORATE	
12	VLAN TAGS	1, 100, 200, 300	
13	USB PORTS	1x USB 2.0 PORT	
14	ETHERNET PORTS	IPQ6018 4X 1GBPS PORTS 1X 2.5GBPS PORT	DR5018S 1X 1GBPS PORTS 1X 2.5GBPS PORT
15	WIREPAS ENABLED	YES	
16	WI-FI ANTENNAS	IPQ6018 2X 2.4GHz INTERNAL 2X 5GHz INTERNAL	DR5018S 2X 2.4GHz EXTERNAL 2X 5GHz EXTERNAL

IMPORTANT

- All installations must conform to local building and electrical codes and shall be in accordance with the **National Electric Code, ANSI/NFPA 70**.
- When discrepancies exist between local codes and this manual, local code takes precedence.
- Follow recommended UL installation standards. Find the standards catalog here: [Standards Catalog | UL Solutions](#)
- Improper installation or usage may affect any otherwise eligible hardware protection coverage.



WARNINGS

Disregarding any warning in this document may void any hardware coverage in place at the time of installation.

OVERVIEW

The OpenTech Alliance, Inc. **INSOMNIAC® OpenNet** is a purpose-built **Wi-Fi mesh network** designed specifically for the storage industry. Powered by Wirepas mesh technology, OpenNet delivers reliable wireless coverage across an entire storage facility, ensuring seamless communication between devices such as sensors, H-VAC control, cameras, and mobile devices.

INSTALLATION MANUAL

INSOMNIAC® OpenNet™

Each OpenNet deployment allows operators to manage three dedicated network segments – IoT (Internet of Things, referring to various connected devices), Guest, and Corporate – from a single system. This structure provides maximum security, performance, and flexibility:

- **IoT Network** – Optimized for sensors, thermostats, and other on-site IoT devices that require highly reliable connectivity.
- **Guest Network** – Provides convenient Wi-Fi access to tenants while keeping corporate and IoT traffic isolated for security.
- **Corporate Network** – A secure, high-performance channel for facility staff and back-office operations.

OpenNet is centrally managed through the **OpenTech IoE Control Center** (Internet of Everything Control Center) – OpenTech's online management platform where you configure and monitor all your connected devices, giving operators visibility into network health, device status, and security events. Facilities benefit from a **self-healing, scalable** network architecture that expands automatically as new OpenNet Access Points and devices are added. With OpenNet, storage operators gain a modern wireless foundation that enhances facility **security**, supports tenant **convenience**, and simplifies IT management—all tailored to the unique requirements of self-storage environments.

Also refer to related guides and manuals in OpenTech's [Resource Library](#) and [Help Center](#).

CONTACT US

Customer Onboarding and Technical Support (US-based, available 24/7)

Phone (US)	602-773-1700 For installation help, select Onboarding For post-installation help, select Technical Support
Phone (Non-US)	Click the Website Support link to find your contact details
Website	https://opentechalliance.com/support/
Email	support@opentechalliance.com

Business Development

Planning assistance for your OpenNet system is available from your assigned Business Development Manager (BDM). Check OpenTech's [Territory Map](#) or call the **Sales Team at 800.419.2006**.





Looking for an authorized installer?

Click the link or QR code to find Authorized Dealers in your area who sell and service OpenTech's INSOMNIAC® self-storage solutions <https://opentechalliance.com/dealers/>



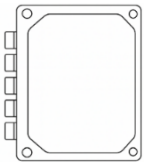
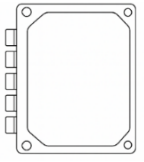

INSTALLATION MANUAL

INSOMNIAC® OpenNet™

PACKAGE CONTENTS

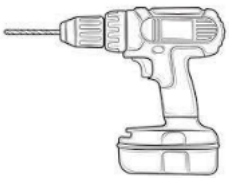
<p>INSOMNIAC® OpenNet Edge Router (ER) (quantity per order)</p> 	<p>INSOMNIAC® OpenNet Access Point (AP) (quantity per order)</p> 	<p>USB Dongle/s (one per device)</p> 
---	---	--

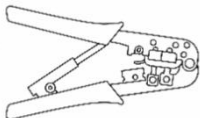
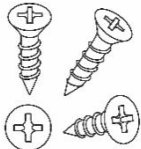
TOOLS & MATERIALS REQUIRED FOR INSTALLATION

<p>Drill Driver</p> 	<p>Drill Bits</p> 
<p>Ethernet Cable Crimping Tool</p> 	<p>Mounting Hardware Specific to Your Mounting Location</p> 
<p>Ethernet Cable</p> 	<p>Other Requirements To connect to the IoE Control Center for testing of connectivity and communications, you will need a laptop and internet access. Go to: OpenTech IoE Control Center</p>

POWER OPTIONS

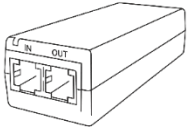
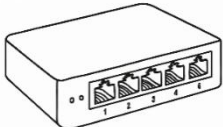
<p>PoE+ Power Adapter/Injector</p> 	<p>PoE+ Networking Switch (Minimum Budget of 30 watts per device)</p> 
--	---



WARNING! PoE+ power equipment is **required** for installation but is **not included** and must be purchased separately

MOUNTING OPENNET

For assistance **during installation** please contact our customer **Onboarding** team.
Phone: 602.773.1700 | **Email:** ioeonboarding@opentechalliance.com



Each OpenNet Edge Router and OpenNet Access Point must be mounted on a flat surface or an elevated pole with no immediate obstructions that might block wireless radio signals. **Always mount the device with the antennas pointing upward.** Choose a mounting method appropriate for your surface type (e.g., drywall anchors for interior walls, weatherproof screws for exterior surfaces). If you are unsure, consult a qualified installer.

Ensure that OpenNet Edge Routers (ER) and OpenNet Access Points (AP) have a **clear line of sight** as much line of sight as possible when relying on wireless transmission. Verify that the mounting location is **free from obstructions** and has sufficient clearance from nearby pathways.

Mount the OpenNet Edge Router or OpenNet Access Point (AP). Position the enclosure on the wall, ensuring the **antennas are on top** of the enclosure. Insert mounting screws through the designated mounting holes. Tighten the screws securely to prevent any looseness.
(Fig.1)

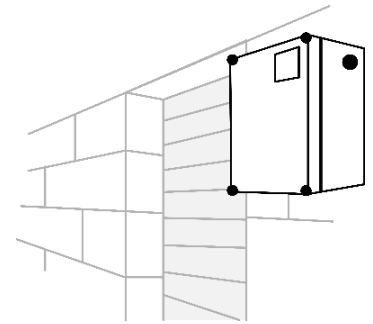

Figure 1

Feed the PoE+ (Power over Ethernet Plus) – a single cable that supplies both power and internet data to the device, eliminating the need for a separate power outlet, cable **through the ½” conduit fitting** into the enclosure. **Connect the Ethernet cable to the single 2.5Gbps port.** Confirm that the enclosure is **firmly attached** to the surface and that no screws or fittings are loose.
(Fig. 2)

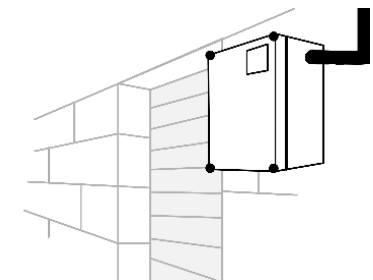

Figure 2



WARNING! OpenNet requires a **permanent internet connection**. We strongly advise against using a hotspot during onboarding.

INSTALLATION RECOMMENDATIONS

Purpose and Scope

A successful OpenNet deployment depends not only on correct physical installation but also on **the order in which devices are brought online, the quality of the power and network equipment feeding them, and the VLAN structure at the site.**

Because OpenNet is a self-healing Wirepas and Wi-Fi mesh, the network needs time to absorb each new device, choose a routing path, and receive configuration from the OpenTech IoE Control Center. Following the sequence below will prevent avoidable connectivity issues, undersized PoE+ budgets, and VLAN mismatches during installation. Go slow to go fast.

OpenTech Recommendations at a Glance

- **PoE+ only, 30 W per device.** Use PoE+ (IEEE 802.3at, 48–56 V) switches or injectors and budget a minimum of 30 watts per OpenNet device. **Standard PoE (802.3af, ~15.4 W) is not sufficient** and will cause unstable boots or random reboots.
- **Unmanaged PoE+ switches preferred.** OpenTech recommends unmanaged PoE+ switches for OpenNet deployments. They require no on-site configuration, eliminate the most common source of installer error, and let the OpenNet Edge Router handle VLAN tagging and segmentation.
- **Untagged + tagged VLANs.** OpenNet uses VLAN 1 as the untagged (native) VLAN and VLANs 100, 200, and 300 as tagged VLANs for the Guest, IoT, and Corporate networks respectively. Any managed switch or upstream ISP equipment that is involved must allow these tags to pass through.
- **Verify before mounting:** always confirm each device is Online in the **IoE Control Center** before mounting it permanently.
- Stage devices one at a time: **Edge Router first**, then each Access Point.

PHASE 1 – Delivery and Inspection

Complete this phase as soon as the shipment arrives, ideally before installation day. **For any shipping or delivery issues (shortages or damages), contact the customer Onboarding team right away (602.773.1700).**

Step 1.1 – Inspect the outer packaging.

- Look for crushed corners, punctures, water staining, or signs that boxes were dropped.
- Photograph any visible damage to the outer packaging before opening. These photos will be required if a damage claim needs to be filed.

Step 1.2 – Verify quantities against the packing list.

- Confirm the count of OpenNet Edge Routers (ER), OpenNet Access Points (AP), USB dongles (one per device), and any antennas (DR5018S boards use external antennas).

Step 1.3 – Inspect each OpenNet device for shipping damage.

Before powering up any OpenNet device, check for:

- Cracks, chips, or stress marks in the IP67 enclosure.
- Damaged or missing antenna connectors (DR5018S external antennas).
- Moisture, dirt, or corrosion inside the enclosure or around the conduit fitting.

Step 1.4 – Verify USB dongles and antennas.

- Confirm one USB dongle per device. The dongle must be plugged into the only USB port for the radio to function.
- For DR5018S boards, confirm two 2.4 GHz and two 5 GHz external antennas are present and undamaged.

Step 1.5 – Stage inspected units.

- Keep devices unpowered during staging. Do not plug PoE+ cables in yet.
- Group devices by the building or area where they will be installed to simplify the staged power-on in Phases 4 and 5.

PHASE 2 – Site Survey and Pre-Installation Planning

Plan placement before drilling any holes. OpenNet only performs well when the Edge Router and Access Points are positioned within the supported wireless ranges and/or have a viable path back to a wired uplink.

Step 2.1 – Identify the Edge Router location.

- Place the OpenNet Edge Router where the facility's internet service (ISP handoff) terminates, or in a location that can be reached by an Ethernet run from that handoff.
- Choose a location with good line of sight into the rest of the facility whenever possible.
- The Edge Router requires an internet connection on its 2.5 Gbps port (LAN port). Access Points receive their internet connection from the Edge Router and must not be fed internet from any other source.

Step 2.2 – Choose a deployment topology.

Decide which of the four supported network topologies you will use at this site. All four are documented in detail later in this Manual. The options are:

1. **Fully wired.** Wired (Ethernet) connection between every OpenNet device for the best quality connection.
2. **Fully wireless.** Power each Access Point (AP) via a PoE+ injector and rely on the wireless mesh.
3. **Hybrid.** Some APs are wired to a centralized PoE+ switch; others extend the mesh wirelessly.
4. **Wireless with tethering.** Two APs connected directly by Ethernet to bridge thick barriers or between floors.

PHASE 3 – Power and Network Equipment Preparation

This is the single most important phase to get right. Undersized PoE+ or a misconfigured managed switch will cause devices to boot unreliably, drop off the mesh, or never reach the IoE Control Center. OpenTech's recommendations are designed to eliminate these failure modes.

Step 3.1 – Use PoE+ equipment with a 30 W budget per OpenNet device.

- Per-device budget. Reserve at least 30 W per OpenNet device in your PoE+ source.
- Switch sizing. Add up 30 W per port you intend to power and confirm the switch's total PoE+ budget exceeds that number. *Ex: four OpenNet devices require at least 120 W of PoE+ budget on the switch.*
- Injectors. If using PoE+ injectors instead of a switch, each injector must be a PoE+ (802.3at) model rated for 30 W or higher.



WARNING! Underpowered ports cause intermittent reboots, mesh instability, and devices that appear Online for a before going Offline. These symptoms are difficult to diagnose and are almost always traced back to a non-PoE+ switch or injector or underpowered devices.

Step 3.2 – Use unmanaged PoE+ switches for easiest setup.

Recommended for the vast majority of OpenNet deployments, unmanaged PoE+ switches require no on-site configuration, cannot be misconfigured, and let the OpenNet Edge Router own the VLAN and segmentation behavior end-to-end.



- **Why unmanaged:** Unmanaged switches pass all traffic (including tagged VLAN traffic) through transparently. This is exactly what OpenNet needs between the Edge Router and the Access Points.
- **WARNING! If a managed switch is already in place:** If the site has an existing managed switch, it must be configured so the OpenNet path is effectively transparent: the ports connected to the Edge Router and Access Points should be trunked and must allow VLAN 1 untagged plus VLANs 100, 200, and 300 tagged (see Step 3.3).

Step 3.3 – Plan VLANs: untagged VLAN 1, tagged VLANs 100, 200, 300.

OpenNet uses a single untagged (native) VLAN for Wirepas, plus three tagged VLANs that map to the Corporate, Guest, and IoT networks exposed by the Edge Router.

VLAN ID	Tag Type	Network	Purpose
VLAN 1	Untagged	Native / Management	Default untagged traffic and device management.
VLAN 100	Tagged	Guest	Tenant-facing Wi-Fi, isolated from Corporate and IoT.
VLAN 200	Tagged	IoT	Cameras, and other connected devices.
VLAN 300	Tagged	Corporate	Facility staff and back-office systems.

- **Untagged traffic:** VLAN 1 is the untagged (native) VLAN. Any traffic that is not tagged with 100, 200, or 300 is treated as VLAN 1.
- **Tagged traffic:** VLANs 100, 200, and 300 are tagged. They must remain tagged all the way from the OpenNet Edge Router to the OpenNet Access Points.
- **Upstream ISP:** Verify that the upstream ISP or firewall will pass these VLAN tags or will at least pass the untagged traffic needed for internet access. Coordinate with the ISP in advance if the handoff is a managed router.

Step 3.4 – Prep cables and mounting hardware.

- Feed each PoE+ cable through the ½" conduit fitting on the OpenNet enclosure. Do not pinch or kink the cable at the conduit entry.

PHASE 4 – Edge Router Installation and Internet Bring-Up

Install the Edge Router first! Until it is online in the IoE Control Center, Access Points have nothing to join.

Step 4.1 – Place, but do not mount, the Edge Router.

- Set the Edge Router in its planned location with the antennas pointing upward.
- Leave the enclosure unmounted. If coverage testing in Phase 6 reveals a better location, you will want to move it.

Step 4.2 – Connect the internet uplink.

- Connect the ISP handoff (modem, ONT, or upstream firewall) to the Edge Router's 2.5 Gbps port (LAN port). This port is both the PoE+ input and the internet uplink.
- On an IPQ6018 board, Port 0 is the designated tethering port when redistributing internet to downstream devices. On a DR5018S board, Port 1 is the designated tethering port.

Step 4.3 – Power up the Edge Router.

- Apply PoE+ power via the 2.5 Gbps port (LAN port) (either from a PoE+ injector or a PoE+ switch port with at least 30 W of budget).
- Confirm the power LED illuminates and network-activity LEDs begin blinking within 30 seconds.
- Allow up to 15 minutes for the Edge Router to negotiate with the mesh, pull configuration, and appear Online in the IoE Control Center. The device may reboot once or twice during this period. This is normal.

Step 4.4 – Verify Online status.

- In the IoE Control Center, confirm the Edge Router reports Online. Go to: [OpenTech IoE Control Center](#).



WARNING! Do not provide internet from external sources into OpenNet Access Points. Internet is provided only through the Edge Router. An external internet connection on an Access Point can result in no connectivity or loss of communication with the Edge Router.

PHASE 5 – Staged Access Point Deployment

Bring Access Points online one at a time. Each new AP should reach Online status before the next one is powered up so the mesh can balance itself cleanly.

Step 5.1 – Select the first Access Point.

- Choose the AP closest to the Edge Router, or the one with the clearest line of sight back to it.
- Place the AP in its planned location with antennas pointing upward. Do not mount it yet.

Step 5.2 – Provide PoE+ power.

- Apply PoE+ via the AP's 2.5 Gbps port (LAN port). Use a PoE+ injector or an unmanaged PoE+ switch with at least 30 W of budget per port.
- Confirm the power LED illuminates and the 2.5 Gbps port (LAN port) LED blinks to indicate activity.

Step 5.3 – Wait for the AP to join the mesh.

- Allow up to 10 minutes for the AP to find the Edge Router, pull configuration, and report Online in the IoE Control Center.
- Expect a reboot or two during this period. The AP may appear unresponsive briefly while it updates.

Step 5.4 – Repeat for each remaining Access Point.

- Power up the next AP, wait for Online, then continue.

PHASE 6 – Mesh Validation and Permanent Mounting

Only mount each OpenNet device once it has been confirmed Online in its final location. Mounting before validation is the fastest way to end up with a device bolted in the wrong spot.

Step 6.1 – Confirm every device is Online.

- In the IoE Control Center, review the device list and confirm every Edge Router and Access Point reports Online.

Step 6.2 – Mount each device.

1. Position the enclosure on the wall (or pole) with the antennas on top.
2. Insert mounting screws through the designated mounting holes.
3. Tighten screws securely to prevent any looseness.
4. Feed the PoE+ cable through the ½" conduit fitting into the enclosure.
5. Reconnect the Ethernet cable to the 2.5 Gbps port (LAN port).
6. Confirm the enclosure is firmly attached and all fittings are tight.



WARNING! Mount devices with antennas pointing upward and with the clearest possible line of sight. Free the mounting location from obstructions and keep clearance from nearby pathways where the enclosure could be struck.

PHASE 7 – Final Facility Verification

Complete this phase only after every OpenNet device is mounted and every SSID is confirmed live.

Step 7.1 – Review the full device list in the IoE Control Center.

- Confirm every Edge Router and Access Point assigned to the facility reports Online.

Step 7.2 – Investigate any stragglers.

- For any device showing Offline or unreachable more than 30 minutes after it was powered on:
- Check the LED state at the device. Refer to the IPQ6018 or DR5018S LED legend in the Installation Manual.
- Verify the 2.5 Gbps (LAN) PoE+ input has power and the cable is fully seated.
- Confirm the USB dongle is plugged in and any required external antennas (DR5018S) are attached.
- Confirm the device is within range of at least one other OpenNet device (200 m with line of sight, 100 m without).
- Power-cycle the device by disconnecting the 2.5 Gbps cable for 30 seconds, then reconnect.

Why This Matters

- **Predictable power.** PoE+ with 30 W of headroom per device eliminates the most common source of flaky OpenNet behavior: under-powered ports. Devices either power on and stay up, or they don't – no mystery reboots at 3 a.m.
- **Easier setup.** Unmanaged PoE+ switches cannot be misconfigured. Installers stop chasing VLAN ghosts and the Edge Router owns the VLAN logic end-to-end.
- **Reliable day-one service.** SmartLocks, SmartMotion, and tenant Wi-Fi all depend on OpenNet. A disciplined installation means the rest of the facility's Smart Devices come online without drama.

MESH COMMUNICATIONS FOR SELF STORAGE

The **INSOMNIAC® OpenNet Mesh Network** is a purpose-built wireless and wired infrastructure that brings enterprise-grade networking to self-storage facilities. **Unlike off-the-shelf Wi-Fi systems**, OpenNet is designed specifically to support the operational, security, and tenant-experience needs of storage operators.

At the center of the wireless network is the **OpenNet Edge Router, which acts as the main hub** – collecting signals from all devices and sending that information to the cloud. The OpenNet Edge Router provides the secure gateway between the local facility and the cloud, ensuring that each of the **three networks—Corporate, Guest, and IoT**—remains isolated, protected, and optimized for its purpose. This architecture simplifies management and enhances security by ensuring that sensitive staff systems, **tenant Wi-Fi**, and facility devices never interfere with one another.

Each OpenNet Edge Router connects directly into the **OpenTech IoE Control Center, a cloud-based** management platform that serves as the single point of configuration and monitoring for the facility’s entire network. From the IoE Control Center, operators can define network rules, monitor device status, troubleshoot connectivity, and review activity logs—all from any internet-connected device. This **centralized** approach removes the complexity of managing individual devices or separate networks on-site, replacing it with a unified, easy-to-use interface.

Extending out from the OpenNet Edge Router are the OpenNet Access Points (Fig. 3), which automatically form a **self-healing Wi-Fi mesh** (meaning if one device loses power or goes offline, the network automatically reroutes through other devices so nothing stops working). The mesh backbone can be deployed in **multiple ways**: 100% **wireless**, 100% **wired** (where cable is available), or mix both for a hybrid deployment. This flexibility allows OpenNet to adapt to the layout of any facility, from a small **single-building property to a sprawling multi-acre site**. As additional OpenNet Access Points are installed, the network automatically scales, expanding coverage and redundancy without requiring complex manual configuration.

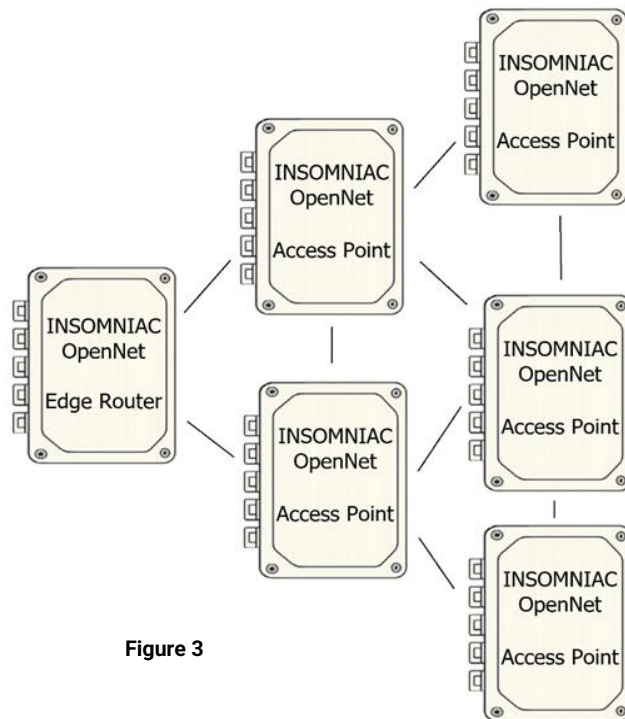

Figure 3

The mesh design ensures that if one OpenNet Access Point goes offline, nearby units automatically reroute traffic through alternative paths, maintaining **uninterrupted service**. Each OpenNet Access Point also provides local coverage for client devices, ensuring that tenants, staff, and facility systems have consistent, reliable access to the network.

By combining segmented networks, **centralized cloud management**, and a scalable mesh backbone, OpenNet delivers a uniquely tailored networking solution to the self-storage industry. Operators gain enterprise-grade connectivity **without the overhead of traditional IT systems**, providing the foundation for SmartLocks, cameras, sensors, tenant Wi-Fi, and future smart facility innovations—all unified under the OpenTech IoT Control Center.

WIRELESS NETWORKS

Each system provides the option to enable up to three wireless networks for the facility, configured through the IoT Control Center by account administrators or with assistance from OpenTech support:

ITEM	NETWORK	5 GHZ AVAILABLE	2.4 GHZ AVAILABLE	SSID
1	IoT	✓	✓	ExampleName_IoT
2	Guest	✓	✓	ExampleName_Guest
3	Corporate	✓	✓	ExampleName_Corporate

PORT CONFIGURATION

The OpenNet Edge Router requires an internet connection. The OpenNet Edge Router provides an internet connection to all OpenNet Access Points. The OpenNet Access Points cannot be provided with a source internet connection outside the designated OpenNet Edge Router.

IPQ6018 Board (Fig. 4)

- **Port PoE+** power and internet both come into the board through this single cable.
 - PoE+ works the same way on both the **Edge Router** and the **Access Point** — power plus internet, one cable.
- **Port 0** is the designated **tethering port** — internet flows out from the board to one connected device.
- **Ports 1, 2, 3** are 1 Gbps ports that provide internet to other devices.
 - For security reasons, these are enabled only on the OpenNet Edge Router.
- **Rule of thumb:** PoE+ brings power and internet *in*. Port 0 sends internet *out*.

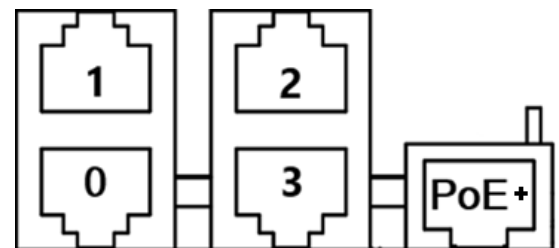

Figure 4

DR5018S Board (Fig. 5)

- **Port PoE+** power and internet both come into the board through this single cable.
 - PoE+ works the same way on both the **Edge Router** and the **Access Point** — power plus internet, one cable.
- **Port 1** is the designated **tethering port** — internet flows out from the board to one connected device.

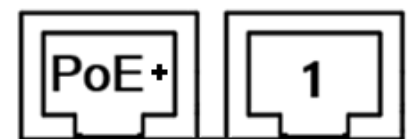

Figure 5

- **Rule of thumb:** PoE+ brings power and internet *in*. Port 1 sends internet *out*.

WIRELESS RANGE AND PLACEMENT

When positioning OpenNet Access Points, ensure they are distributed as evenly as possible to maximize coverage. This will help ensure that every device maintains a strong connection to its nearest OpenNet Access Point. Refer to the examples provided at the end of this section for guidance.



WARNING! It is highly recommended to **verify connectivity prior to mounting any OpenNet device**. A successfully connected device will appear as 'Online' in the IoE Control Center dashboard. In the event a device has little (or no) connection to the mesh, relocation of the device may be necessary.

To begin setting up OpenNet, first place the OpenNet Edge Router in the desired location within the facility. Power it on, connect it to the internet, and confirm that it is functioning correctly. At this stage, the OpenNet Edge Router should remain unmounted so that its position can be adjusted later if necessary.

Once the OpenNet Edge Router is online, proceed to place the first OpenNet Access Point. Choose a location that provides good line of sight and optimal coverage for the area you want to serve. Power on the OpenNet Access Point and check its status in the IoE Control Center to verify that it has successfully connected. If the OpenNet Access Point does not appear online, reposition it until the connection is established.

After the first OpenNet Access Point is confirmed, repeat the same process for all additional OpenNet Access Points. Each unit should be placed to maintain clear communication with either the OpenNet Edge Router or another OpenNet Access Point already on the mesh. As each OpenNet Access Point is powered on and connected, the system will expand and balance itself, creating a resilient, self-healing network across the facility.

Assistance with planning your OpenNet system is available from your assigned Business Development Manager (BDM). Check OpenTech's [Territory Map](#) or call the **Sales Team at 800.419.2006**.

WIRELESS NETWORK WITH OPENTECH'S SMART DEVICES

When considering placement of the OpenNet devices with OpenTech's INSOMNIAC® SmartLock or SmartMotion devices, follow these rules:

Rule 1: The OpenNet Edge Router and OpenNet Access Points must have the ability to maintain a connection path with at least two separate OpenNet Access Points or an OpenNet Access Point and an OpenNet Edge Router.

Rule 2: Each OpenNet Edge Router and OpenNet Access Point **WITH** a clear line of sight must be no more than ±200 meters (656 feet) away from another OpenNet Access Point.



Rule 3: Each OpenNet Edge Router and OpenNet Access Point **WITHOUT** a clear line of sight must be no more than ±100 meters (328 feet) away from an OpenNet Access Point that **DOES HAVE** a clear line of sight.

Rule 4: Each OpenNet Edge Router and OpenNet Access Point can support approximately 100 Smart Devices.

Rule 5: Each OpenNet Edge Router and OpenNet Access Point must have a minimum of 2 Smart Devices **WITH** a clear line of sight.

NETWORK CONFIGURATION SCENARIOS

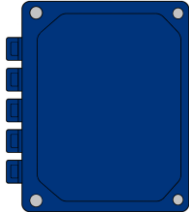
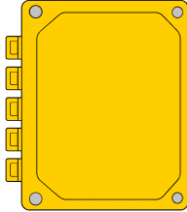
Each scenario contains at minimum (1) OpenNet Edge Router and (1) OpenNet Access Point. Refer to the component table below.

INSOMNIAC® OpenNet Access Point		INSOMNIAC® OpenNet Access Point	
PoE+ ADAPTER/INJECTOR		PoE+ NETWORK SWITCH	

Scenario 1 - Fully Wired System

To ensure the best quality connection between every OpenNet Access Point, provide a wired connection between every point.

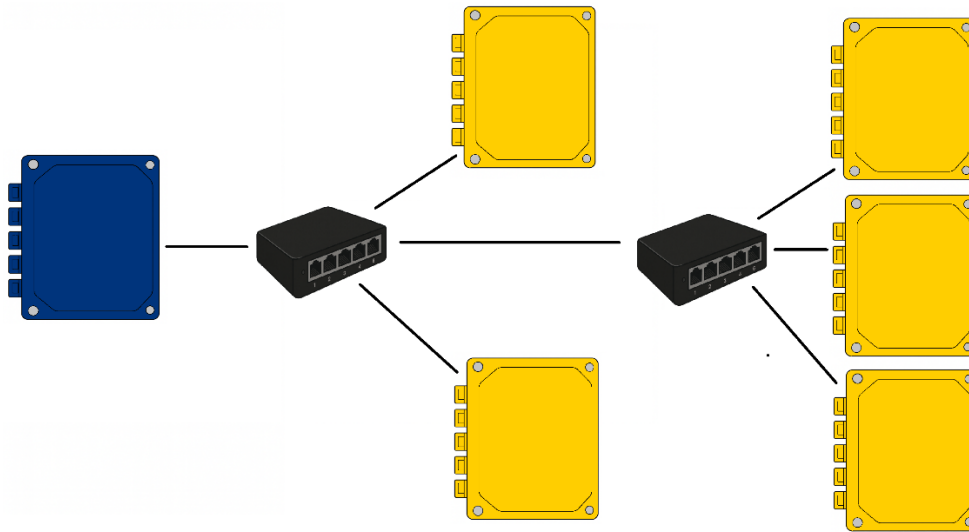

Figure 6

Scenario 2 - Fully Wireless System

If there is no option to run wire, use the wireless mesh connection between devices by powering multiple OpenNet Access Points via a PoE+ injector.

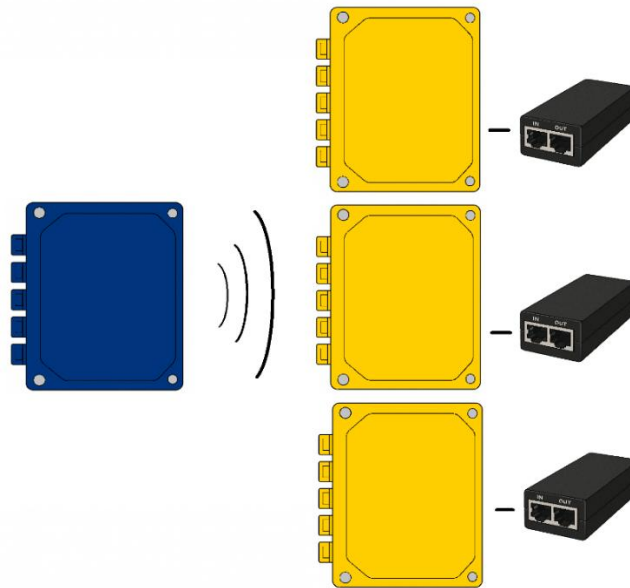

Figure 7

Scenario 3 - Hybrid Wireless + Wired System

In this scenario there are two OpenNet Access Points that can be wired back to a centralized switch that is wired to the OpenNet Edge Router. The network can be expanded wirelessly to areas that cannot be wired, by providing power to additional OpenNet Access Points via a PoE+ injector.

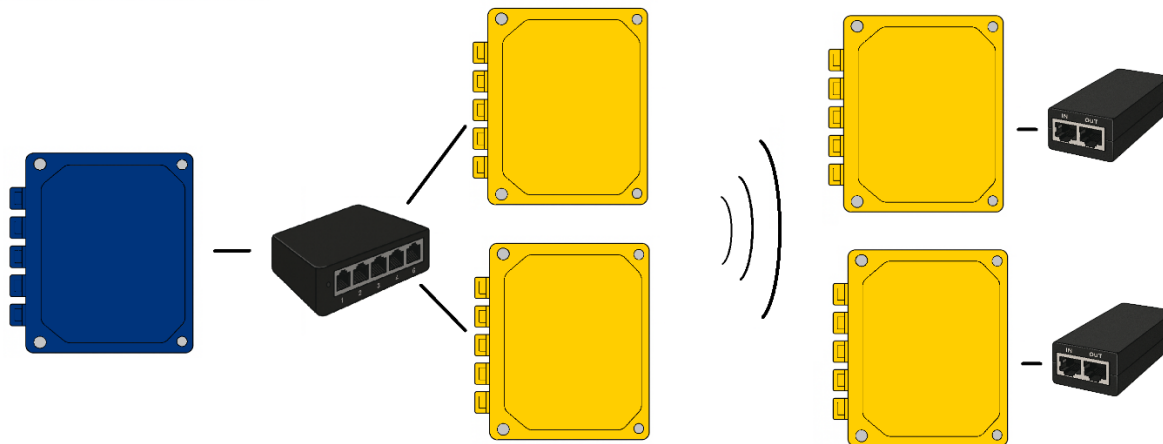

Figure 8

Scenario 4 - Wireless System with Tethering

This scenario uses the tethering feature to connect two OpenNet Access Points together. This will provide internet access from one OpenNet Access Point to another. This is especially helpful for providing a connection between thick barriers or between floors.

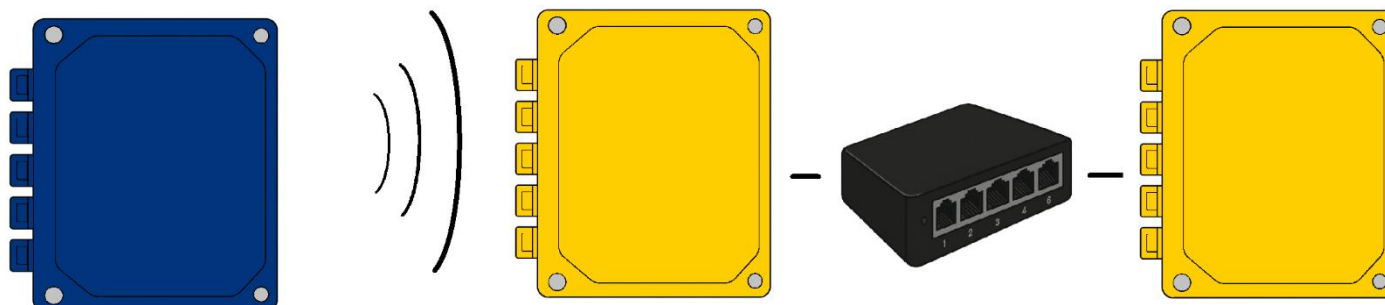
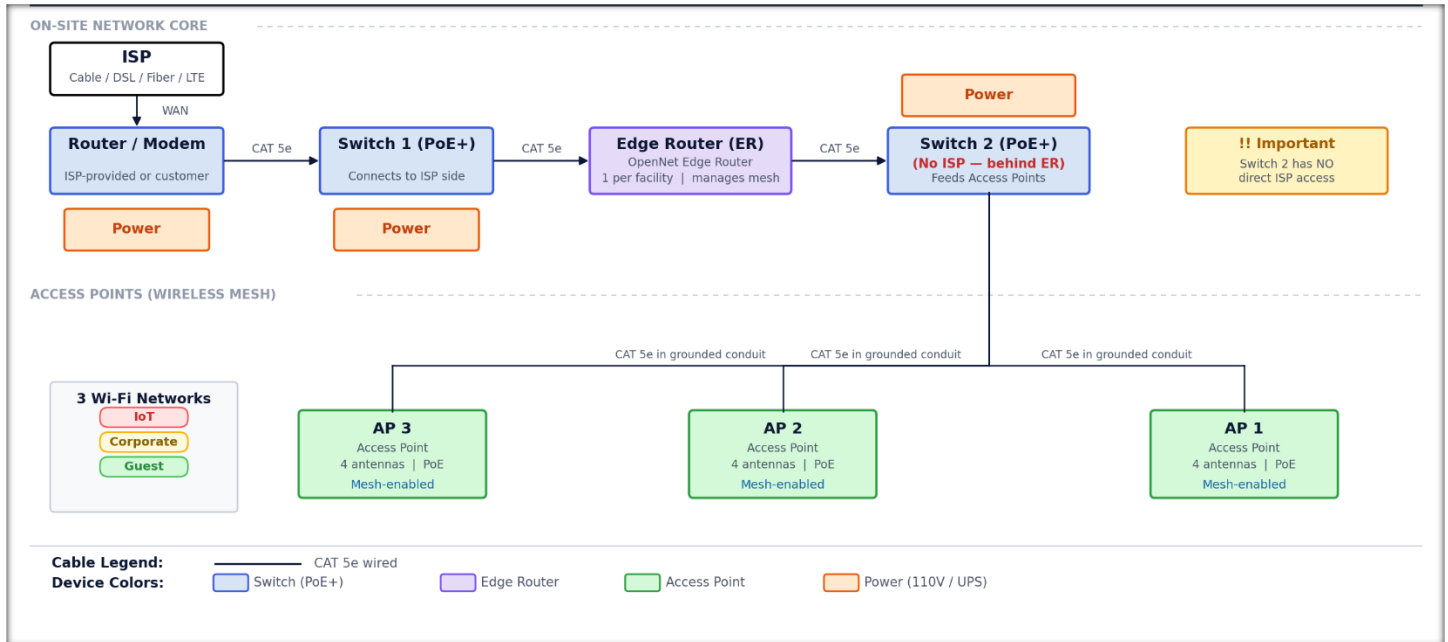

Figure 9

Tethering Configurations

The following configurations are the valid ways to tether the Edge Router and Access Points together. Tethering, in this context, means connecting two OpenNet devices directly with an Ethernet cable so that one device shares its internet connection with the other.



Example Fully Wired Setup

Configuration 1 – Edge Router Access Point Tethering

The diagrams below illustrate the physical and logical connections required to configure the Edge Router (ER) as an Ethernet tether. In this configuration, the ER provides upstream network connectivity to downstream devices and is typically used when supplying data to either a single Access Point directly or to a network switch that distributes connectivity to multiple Access Points..



Figure 10

5018 configured as an Edge Router with PoE+ injector



Figure 11

6018 configured as an Edge Router with PoE+ injector

Configuration 2 – Access Point Tethered to Another Access Point



Figure 12

5018 configured as an Access Point with PoE+ injector

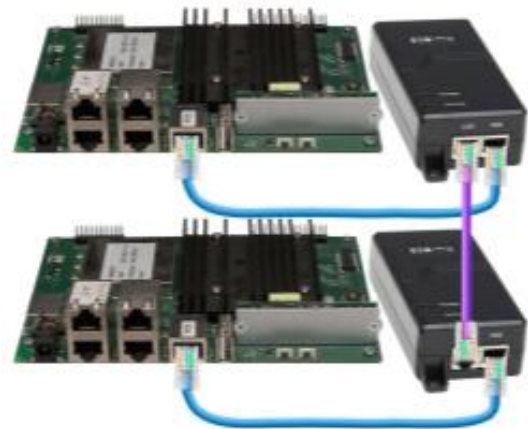

Figure 13

6018 configured as an Access Point with PoE+ injector

This configuration illustrates Access Point (AP) tethering between two Access Points powered by PoE+ injectors. It represents the simplest AP-to-AP tethering setup and is typically used when direct line of sight is not available, requiring a stronger and more reliable wired connection between the devices.

Configuration 3 – PoE+ Enabled Switch

This configuration illustrates multiple Access Points tethered to a PoE+-enabled switch. It is typically used to support many tethered Access Points, allowing centralized power delivery and network distribution from a single switching device.

Note: PoE+ injectors are not required when PoE+ power is provided directly by the network switch.



Figure 14

Multiple 5018's configured as Access Point's using the switch for power and data transfer



Figure 15

Multiple 6018's configured as Access Point's using the switch for power and data transfer

TESTING AND TROUBLESHOOTING

Test each OpenNet device by powering up the device with a PoE+ connection into the 2.5Gbps port. There is an LED Array that will indicate power and activity status (See LED array details specific to your board version below). Once the device is connected to the network you will see activity via the flashing LEDs in the LED array.

Once the OpenNet device's connection has been established, the device will confirm and update its configuration; you may see the device become unresponsive or reboot during this period. Allow up to 15 minutes for the device to fully establish its connection and update its configuration.

To ensure full functionality of the device each device must have:

- Power via PoE+ via the 2.5Gbps port.
- (1) USB Dongle plugged into the only USB port.
- (2) 2.4Ghz network antennas plugged into the network antenna button connectors.
- (2) 5Ghz network antennas plugged into the network antenna button connectors.

Also ensure the OpenNet Edge Router has internet connectivity via the 2.5Gbps port from your local ISP.

To power cycle the device remove power via disconnecting the cable from the 2.5Gbps port for 30 seconds, connect the cable back into the device after the 30 seconds.



WARNING! The main PCB carries a Master ID Address called the UID. If this board is changed out, the new board's UID **must be entered in IoE Control Center**, replacing the previous board's address before the board will function.

Testing of Wi-Fi networks can be achieved by connecting a mobile device to the network. Please ensure that the network SSID and Password have been setup prior to testing.



WARNING! Do not provide internet from external sources into OpenNet Access Points. Internet access is only provided via the OpenNet Edge Router. If an external internet connection is provided to an OpenNet Access Point it can result in **no connectivity to the device or loss of communication** to the OpenNet Edge Router.

For further assistance with troubleshooting your iOpenNet hardware after installation, please reach out to our Technical Support team (602.773.1700).

LED Status Indicators

IPQ6018 LED Statuses

LED ARRAY CONFIGURATION



LED ARRAY

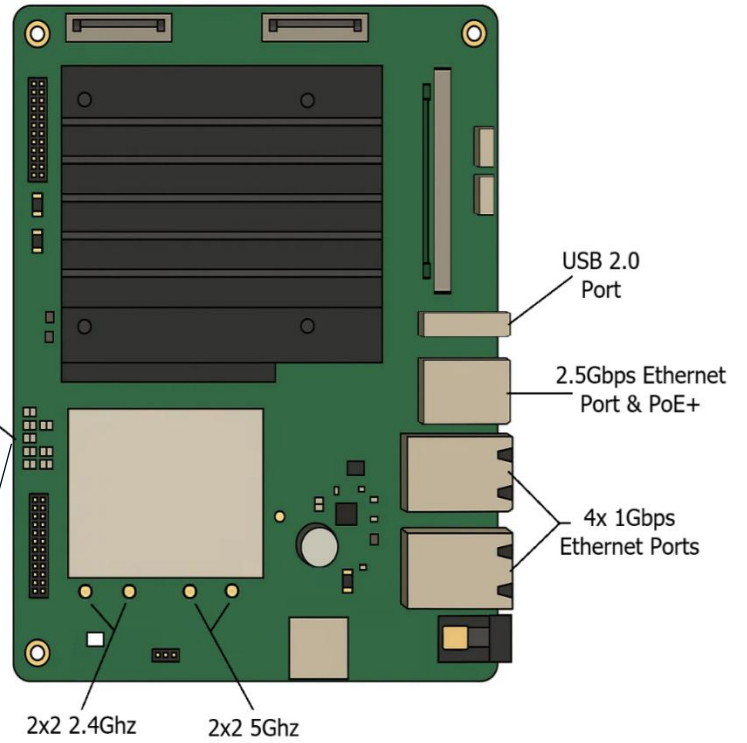

LED ARRAY LEGEND

ITEM	LED	LED DESCRIPTION
1	2	Power
2	4	Debugging (Not in use)
3	3	Debugging (Not in use)
4	5	Network Activity on the 2.5Gbps port
5	7	Network Activity on the 1Gbps port, port three
6	8	Network Activity on the 1Gbps port, port two
7	1	Network Activity on the 1Gbps port, port one
8	6	Network Activity on the 1Gbps port, port zero

DR5018S LED Statuses

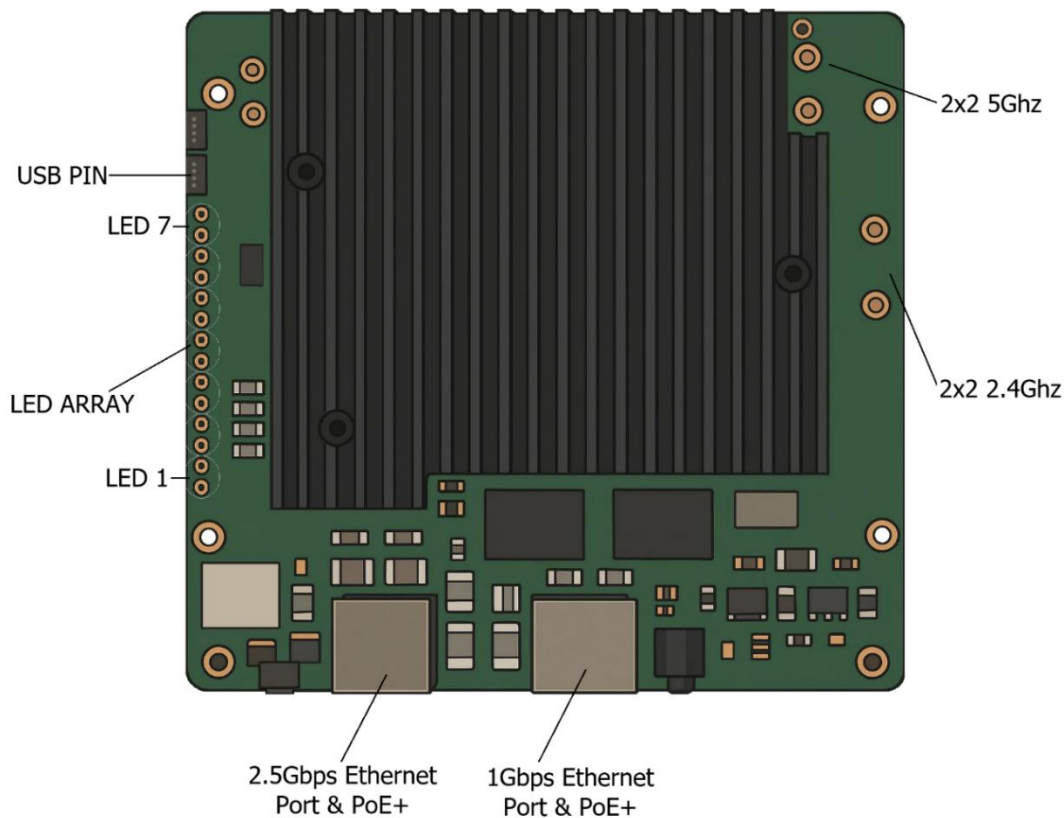

LED ARRAY LEGEND

ITEM	LED	LED DESCRIPTION
1	1	Power
2	2	Network Activity on the 2.5Gbps port
3	3	Network Activity on the 1Gbps port
4	4	Debugging (Not in use)
5	5	Debugging (Not in use)
6	6	Debugging (Not in use)
7	7	Debugging (Not in use)

MAINTENANCE

Inspect and clean the housing periodically to ensure superior performance over time.



- **Do not** use alcohol, harsh chemicals, abrasives, or petroleum-based products.
- **Do not** use a pressure washer.

Annually

- Open the OpenNet Edge Router or OpenNet Access Point housing, inspect and clean inside the unit.
- Remove dirt or dust that has collected on the inside of the housing and the circuit board that could cause operational issues.
- Check for any signs of water damage or corrosion caused by a failure in the enclosure seals. Replace any worn seals.
- Check that all cables are firmly connected and that no components appear burned or discolored
- Use compressed air to blow out debris.

NOTICES AND DISCLAIMERS

FCC Part 15 Notice: The referenced equipment has been tested and found to comply with the limits for a Class B digital device, pursuant to Part 15 of the FCC Rules. These limits are designed to provide reasonable protection against harmful interference in a residential installation. This equipment can generate and radiate radio frequency energy and, if not installed and used in accordance with the instructions, may cause harmful interference with radio communications.

Liability Disclaimer: While every effort has been made to ensure the accuracy of the information in this document, we assume no liability for any inaccuracies contained herein. We reserve the right to change the information contained herein at any time and without notice.