

# INSOMNIAC® CIA

## R-700 Relay Module

P/N CIA-775-001  
Revision 1.4  
Date Code: 05-01-2025

### Contents

INSTALLATION SPECIFICATIONS .....	2
WARNINGS.....	2
OVERVIEW .....	3
HOW TO CONTACT US.....	3
MOUNTING THE R-700.....	4
WIRING DIAGRAM.....	6
POWER/RS485.....	7
WIRELESS INSTALLATION (OPTIONAL) .....	9
RELAY OUTPUTS and INPUTS.....	9
TESTING and TROUBLESHOOTING .....	10
ACCESSING THE DISPLAY PCB & SUBASSEMBLIES.....	11
MAINTENANCE .....	12
NOTICES and DISCLAIMERS.....	12

# INSTALLATION MANUAL

## CIA® R-700 Relay Module

### INSTALLATION SPECIFICATIONS

ITEM	DESCRIPTION	FEATURES
1	ENCLOSURE	INDOOR / OUTDOOR, ALUMINUM, POWER COATED
2	FACEPLATE	ALUMINUM, POWDER COATED
3	LCD	2-LINE (NON-GRAPHIC)
4	COMMUNICATIONS	RS485 OR WIRELESS (900 MHZ)
5	FORM-C RELAY OUTPUTS	8
6	SECURE COMMUNICATIONS	YES
7	TAMPER	YES
8	AUXILIARY INPUTS	8
9	MAX OPERATING VOLTAGE	24VDC
10	MIN OPERATING VOLTAGE	12VDC
11	MAX INPUT CURRENT	2A
12	OPERATING TEMP RANGE	-31 TO 150 DEG. °F
13	HUMIDITY	0-95% NON-CONDENSING
14	INGRESS RATING	UL294 OUTDOOR EQUIPMENT

### IMPORTANT

- All installations must conform to local building and electrical codes and shall be in accordance with the **National Electric Code, ANSI/NFPA 70**. Ref: [The National Electrical Code \(NEC\) - Electrical Safety Foundation International](#)
- When discrepancies exist between local codes and this manual, local code takes precedence.
- Follow recommended UL installation standards. Find the standards catalog here: [Standards Catalog | UL Solutions](#)



### WARNINGS

Disregarding any warning in this document may void any warranties in place at the time of installation.

# INSTALLATION MANUAL

## CIA® R-700 Relay Module

### OVERVIEW

Please read the entire document before proceeding with the installation. It is recommended that installation be performed by a certified, licensed, authorized installation company.

The OpenTech Alliance, Inc. **INSOMNIAC® CIA R-700** is a Relay Module designed to switch devices based on access actions occurring remotely from the secured area. It operates in conjunction with OpenTech's Gateway controller, which contains a list of access codes and areas where they are valid.

The Gateway communicates with OpenTech's Control Center, a master database that exists and is centrally accessible via the internet. This is the system's source of access and configuration information. If internet connectivity is lost, the Gateway will continue to operate using cached data – but no updates in access codes or configuration will be possible until internet connectivity is restored.

The Relay Module is typically used to control elevator access, lighting or other security related functions that are relay driven. In all cases, however, the control logic must be configured in the central Gateway via the Control Center.

The Relay module should be mounted inside a protected area. The unit can be paired with a Keypad to provide additional security by wiring the door strike to the relay unit (located inside the protected area) rather than connecting the strike directly to the keypad (outside a protected area).

Also refer to related guides and manuals in OpenTech's [Resource Library](#) and [Help Center](#).

### HOW TO CONTACT US

#### OpenTech Alliance, Inc. Tech Support

(US-based, available 24/6)

Phone  
Website  
Email

**602-773-1700** (option 2, then option 1)  
[Support - OpenTech Alliance, Inc.](#)  
[support@opentechalliance.com](mailto:support@opentechalliance.com)

#### Looking for a local installer?

Click below to find Authorized Dealers in your area who sell and service INSOMNIAC® self storage solutions?

[Find an OpenTech Dealer - OpenTech Alliance, Inc.](#)

# INSTALLATION MANUAL

## CIA® R-700 Relay Module

### MOUNTING THE R-700

**Open the device** by unlocking the Southco latch on the front of the unit. The front plate is hinged at the left and will swing open.

#### **IMPORTANT**

The Key Switch at the right (Figure 1) is for manually activating relays and is **not used to open the unit**.

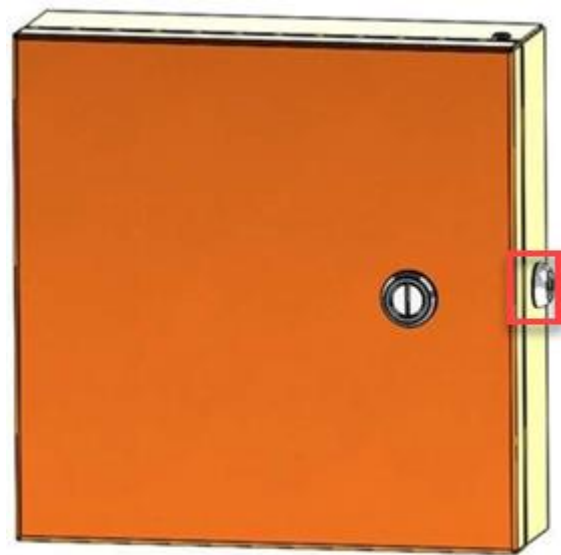

Figure 1

**Mount the back plate** to the desired keypad location using the 4 holes in the back panel that carry grommets. (Figure 2)

#### **If the relay is being mounted on a wall:**

Before mounting, run a bead of outdoor silicone sealant in a square around the back of the enclosure about ½ inch from the edge.

Also run a bead of silicone from the inside seal around each screw hole and the wire entry hole after pulling the wires through.

**Pull the necessary wires** through the wire hole on the back of the housing. Allow ample wire to remain inside the housing.

After the wiring connections are complete, excess wire can be pushed back into the wall or it can be carefully positioned inside the keypad housing for future maintenance and service.

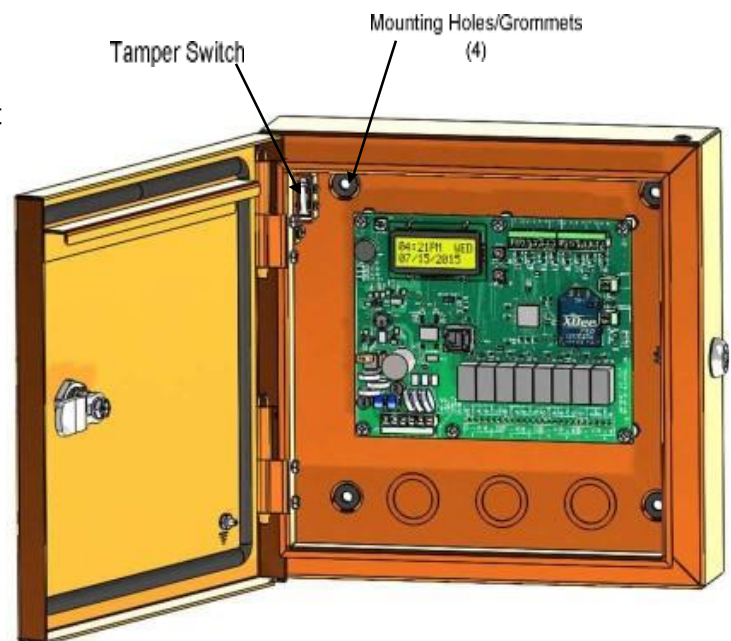

Figure 2

# INSTALLATION MANUAL

## CIA® R-700 Relay Module

### **WARNING**

All wiring voltage, including pre-existing, must be measured prior to wiring it into the RS485 Terminal block. Incoming voltage will damage the board and void any warranty currently in place.

- We recommend that power and RS485 data communications be via a single 18 AWG, 6-conductor shielded cable.
- The shield drain wire may be used as the RS485-common (RS-CMN) wire.
- Do not connect more than two (2) RS485 cables to one PCB.
- All PCBs shall be connected as an inline chain beginning with the controller and ending with the last device.
- The last device on the chain – and only this device – must have a ‘termination’ jumper installed.

 **5 Pin terminal blocks are not compatible with OpenTech's 6 Pin RS485**

**IMPORTANT:** If you use additional power supplies, ensure that the additional power is not back-fed into the Gateway Controller, as this will damage the board.

# INSTALLATION MANUAL

## CIA® R-700 Relay Module

### WIRING DIAGRAM

All installations must conform to local building and electrical codes and shall be in accordance with the Nation Electric Code, ANSI/NFPA 70. Local codes takes precedence over instructions in this manual.

**Figure 3** is a connection diagram for the Relay Printed Circuit Board (PCB). All cables entering the gateway must be insulated and shielded with drain wires connected to earth ground at one end. In addition, incoming cables other than the RS485 cables must be less than 10 meters long. The R485 wires should be 18 gauge. Other wires must be between 16 and 26 gauge. An 18g 6 Conductor shielded cable is recommended for RS485 data & power.

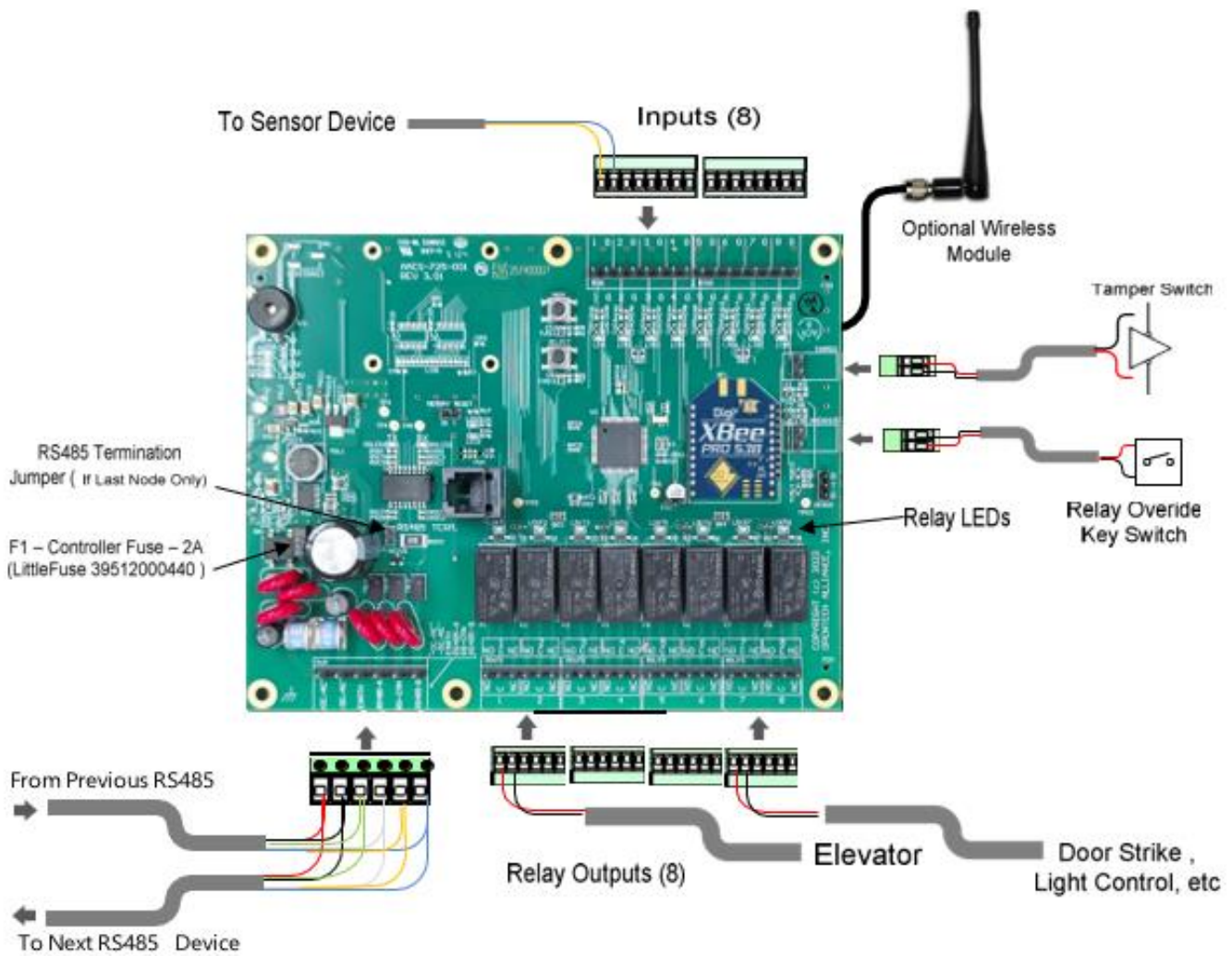

Figure 3

# INSTALLATION MANUAL

## CIA® R-700 Relay Module

### POWER/RS485

Power and RS485 data communication is handled with a single connector. This is the last connector to be attached because it may carry active power. We recommend:

- Power and RS485 data communication be via a single 18 AWG, 6-conductor shielded cable.
- The shield drain wire may be used as the RS-CMN wire.
- Do not connect more than two (2) RS485 cables to one PCB.
- Connect all PCBs as an inline chain beginning with the Gateway and ending with the last device.
- Install a “termination” jumper on the last device (all other devices have this jumper omitted).

### WARNING

All wiring voltage, including pre-existing, must be measured prior to wiring it into the RS485 Terminal block. Incoming voltage will damage the board and void any warranty currently in place.

- **5 Pin terminal blocks are not compatible with OpenTech’s 6 Pin RS485 and attempts to use them will void the warranty.**
- For any additional power supplies, ensure the additional power is not back-fed into the Gateway controller, as this will damage the board and **void the warranty.**
- Cross-wiring or shorting power wires can damage the circuit board, which will **void the warranty.**

**These RS485 connectors have 6 pins.**

DC +V (12-24VDC)	Required	Red
DC -V (DC Common)	Required	Black
Earth	Required	Green Insulated Copper Wire
RS485-A	Required	White
RS-CMN	Required	Orange
RS-485-B	Required	Blue

### RS485 Requirements

A wired keypad may be located up to 4000 feet from the Gateway give proper wiring. To correctly terminate cables into connectors follow these instructions:

1. Strip back the outer insulation and shield foil from both of the 18 AWG, 6-conductor, shielded cables (coming from the Gateway or previous device in line and going out to the next device in line), being careful not to cut the bare shield wire. Strip ¼ inch of insulation off the end of each of the individual colored conductor wires.
2. Remove the terminal blocks from the door alarm circuit board by sliding them up and off. The terminal blocks may be somewhat difficult to remove, as a tight electrical connection is necessary. If they are tight, rock them slightly back and forth while lifting away from the board.
3. Insert wires into the desired connector. Where 2 wires are tied together, ensure that both wires are seated all the way inside the slot. Use a flathead precision screwdriver to tighten down the terminal screw.

# INSTALLATION MANUAL

## CIA® R-700 Relay Module

4. Verify that the terminal slot has tightened down on the copper wire and not on the rubber insulation. There should be no copper wire showing outside of the terminal slot. Gently tug the wires to verify that they are tightly held inside the terminal slot. Repeat this process with each of the remaining wire connections.

### Earth Grounding

The installation must comply with applicable codes regarding the type of wire used.

#### IMPORTANT

- Uninsulated wires (typically used for earth grounding) must not be located inside the unit's case.
- Make any needed connections for an uninsulated ground wire *outside* the enclosure.
- For all devices except the Gateway, an **insulated copper wire must be connected to the RS-485 terminal labeled "Earth."** This follows the single-point grounding principle, which helps minimize interference and enhances protection against lightning damage.



#### WARNING

- 5 Pin terminal blocks (including PTI) are not compatible with OpenTech's 6 Pin RS485 and attempts to use will **void the warranty**.
- Cross-wiring or shorting power wires can damage the circuit board, which will **void the warranty**.

### Terminating Cables into Connectors

1. Strip back the outer insulation and shield foil from both of the 18 AWG, 6-conductor, shielded cables (coming from the controller or previous inline device and going out to the next inline device), being careful not to cut the bare shield wire. Strip ¼ inch of insulation off the end of each of the individual-colored conductor wires.
2. Remove the terminal blocks from the keypad circuit board by sliding them up and off. The terminal blocks may be somewhat difficult to remove as a tight electrical connection is necessary. If they are tight, rock them slightly back and forth while lifting away from the board.
3. Insert wires into the desired connector. Where 2 wires are tied together ensure that both wires are seated all the way inside the slot. Use a flathead precision screwdriver to tighten down the terminal screw.
4. Verify that the terminal slot has tightened down on the copper wire and not on the rubber insulation. There should be no copper wire showing outside of the terminal slot. Gently tug the wires to verify that they are tightly held inside the terminal slot. Repeat this process with each of the remaining wire connections.

# INSTALLATION MANUAL

## CIA® R-700 Relay Module

### WIRELESS INSTALLATION (OPTIONAL)

OpenTech devices can function without the RS485 wiring. In this case, a Digi XBee or XBee Pro wireless module and an RPSMA antenna must be installed on the Gateway and on the device. If the keypad is within wireless range of the Gateway, it will work as it would with RS485 connections.

The range depends on the wireless module used, the antenna used, the RF background level of the area (rural or urban) and the number of obstructions between devices. The XBee basic module range is rate to 300ft rural (unobstructed line of sight). The typical obstructed range of XBee in urban areas is 100 ft. The XBee Pro module range is up to 1 mile rural (unobstructed line of sight) and 500ft obstructed/urban. XBee Pro transmitter modules are recommended.

*This option has been tested and found to comply with the limits for a Class B digital device, pursuant to Part 15 of FCC Rules. This option has **not** been evaluated nor certified as part of UL294 level 2 nor CSA C22.2 No.205.*

### RELAY OUTPUTS and INPUTS

#### Outputs

Relays have a Normally Closed (NC), Common (COM) and Normally Open (NO) connection. Depending on the need, wire to the COM and either the NC or NO. Onboard LEDs will show if the relay is activated.

Typically, gate operators requires the NO contact while some electric door strikes require the NC contact. If door strikes are used it is recommended they be DC powered (typically 12V) which requires a shunting diode be installed across the solenoid to prevent ground spikes from disrupting keypad communication. **Do not pull power from the RS485 terminal block to power any other device.**

#### Relay Specifications:

Item	Rating
Contact Type	Single Ag-Alloy (Cd Free)
Rated Load	5A (NO) / 3A (NC) @ 30VDC
Max Switching Voltage	30VDC
Max Switching Current	5A (NO) / 3A (NC)

#### WARNING

- Relay voltage must not exceed 30 volts.
- Do not wire the relay to the operating device. This will introduce the operating device control voltage into the Individual Unit Alarm housing, which is not designed to contain high voltage.
- Do not connect a gate operator or door strike to a keypad that is located outside the area it secures.
- Follow UL standards.

#### Inputs

Each Input has a Ground Connection/in and a Sense Connection/pin. Sense connections are marked 1-4 and will source a small voltage at high impedance. Wire any dry contact across a sense pin and a G pin. Closing the contact will energize the input. Onboard LEDs will light up if the input is activated.

# INSTALLATION MANUAL

## CIA® R-700 Relay Module

### TESTING and TROUBLESHOOTING

Test the Relay unit by applying power to the PWR/RS485 connections. An “Offline” message will initially be displayed after power is applied. This is normal.

Once the controller recognizes the device, a standard welcome message will appear. There are also multiple LEDs as shown below that should be active as described for troubleshooting purposes. Check the 3 Power LEDs on the PCB.

- If they are all dark, check/replace the PCB fuse.
- If a single specific power LED such as the 3.3V or 5V LEDs is dark, replace the PCB.

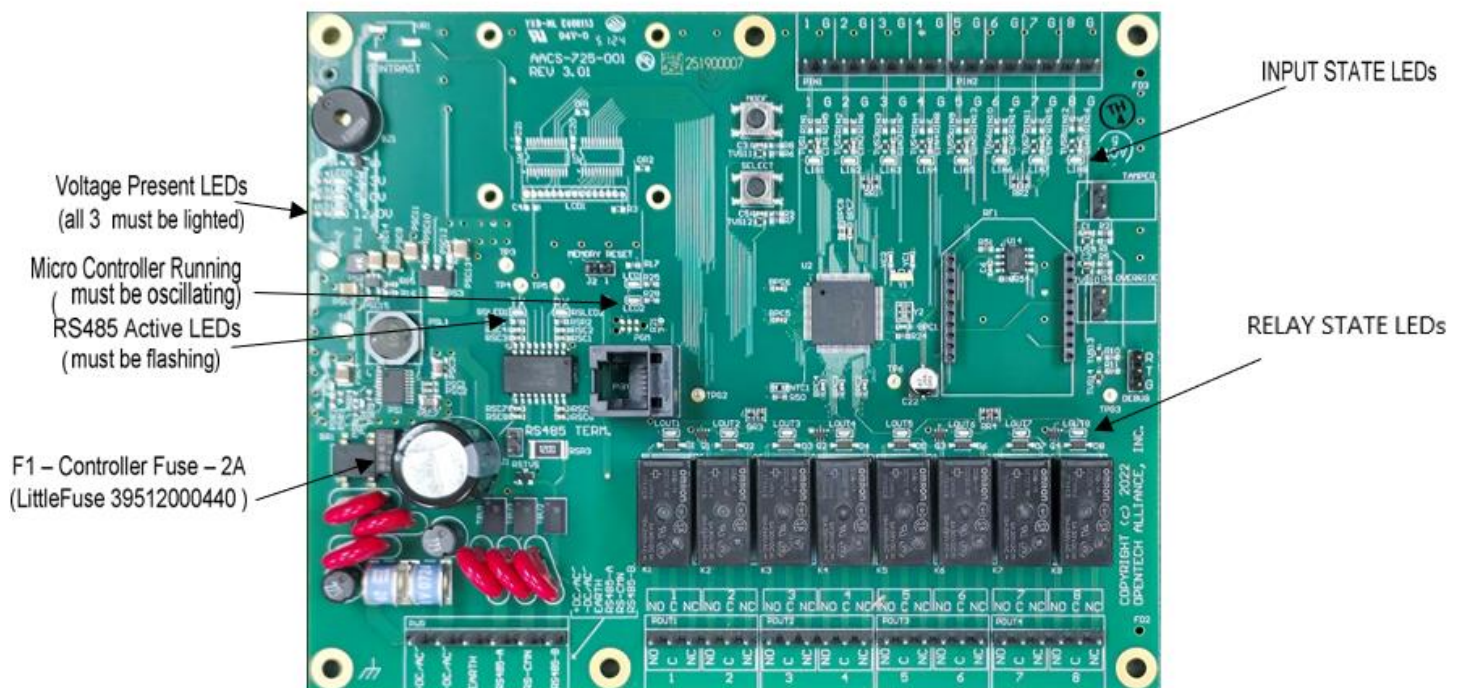

#### Manual Operation Key switch

The override key switch will activate all 8 onboard relays. By default this should be off. If all relays have a RED LED above them, turn the key and they will switch off.

# INSTALLATION MANUAL

## CIA® R-700 Relay Module

### ACCESSING THE DISPLAY PCB & SUBASSEMBLIES

The main PCB is mounted on hinged standoffs. Loosening 4 thumb screws allows the PCB to be folded back in place to access the Display PCB and the metal push button assembly.

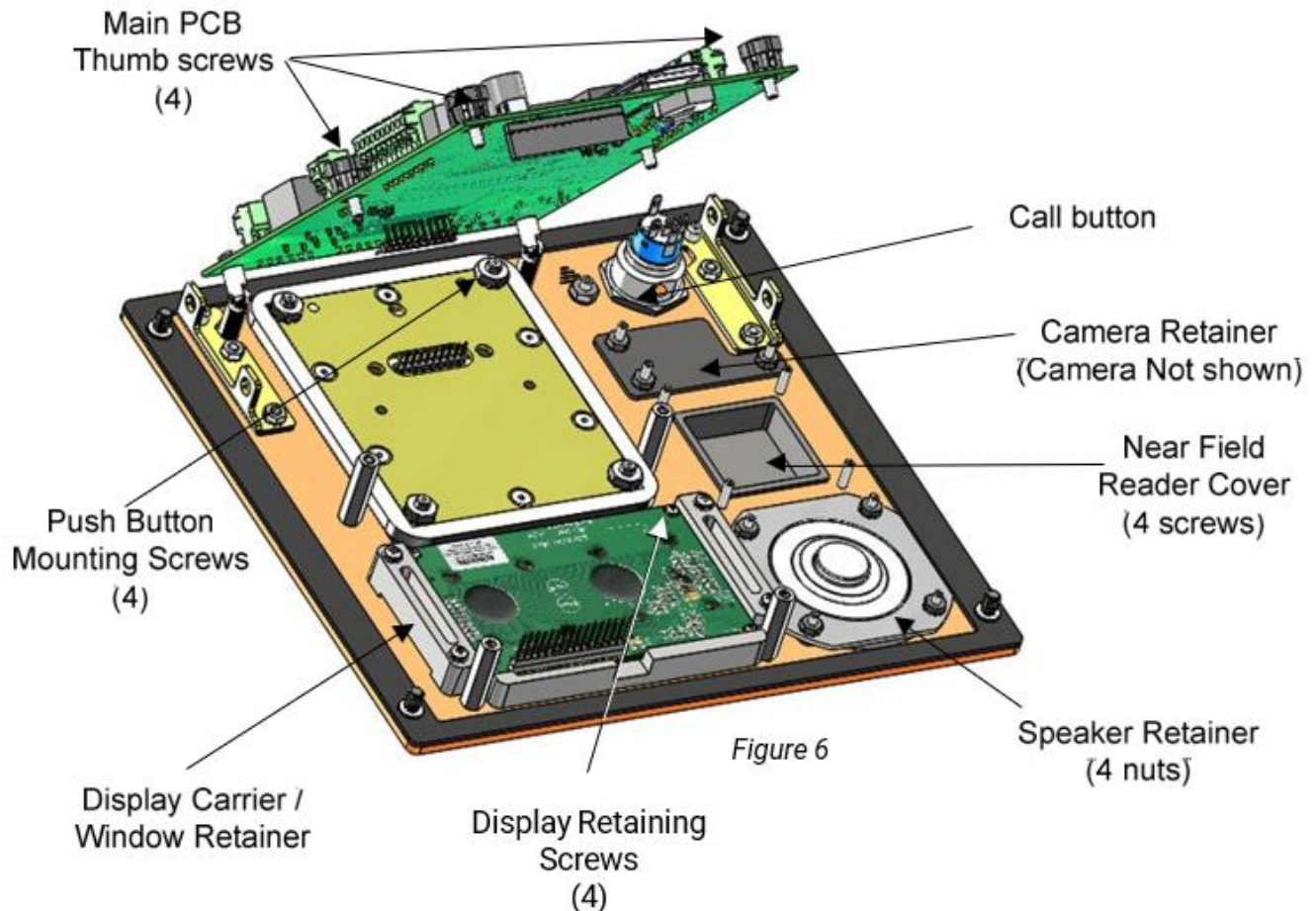

The push button assembly is a single part held in place by 4 nuts in the 4 corners of the unit. Similarly, the display PCB is held to its holder/retainer with 4 Philips head screws. Both can be easily changed after removing the ribbon cable that connects them to the Main PCB.

The Display PCB mounts to a plastic carrier that also acts to hold the display window in place. The carrier can be removed with 4 screws to access the window and the window seal gasket.

The Speaker is held in place with a retainer with 4 nuts. Its face is rubberized and does not need an additional seal.

A plastic cover is provided to allow a near field device such as an iBeacon to be added. While not intended to integrate into the keypad functionally, the separate module can be powered by the Main PCB using the power connections (+5V/+12V) available on the Wiegand connector.

# INSTALLATION MANUAL

## CIA® R-700 Relay Module

### MAINTENANCE

Follow a simple schedule of routine maintenance to keep the system functional and to preserve the warranty.

#### Annually:

- Open the enclosure and inspect the inside of the unit.
- Use compressed air to remove any dust or debris that has collected on the inside of the housing and the circuit board.
- Repair any signs or sources of water damage or corrosion (e.g., a leak in the sealant).
- Replace any worn seals.

### NOTICES and DISCLAIMERS

**FCC Part 15 Notice:** The referenced equipment has been tested and found to comply with the limits for a Class B digital device, pursuant to Part 15 of the FCC Rules. These limits are designed to provide reasonable protection against harmful interference in a residential installation. This equipment can generate and radiate radio frequency energy and, if not installed and used in accordance with the instructions, may cause harmful interference to radio communications.

**Liability Disclaimer:** While every effort has been made to ensure the accuracy of the information in this document, we assume no liability for any inaccuracies contained herein. We reserve the right to change the information contained herein at any time and without notice.