



INSOMNIAC®
331

INSTALLATION **GUIDE**

Installation specifications and considerations for your new INSOMNIAC kiosk. Never miss another rental.

CONTACT US

Each INSOMNIAC® full-service kiosk is a self-contained system designed for easy installation. An OpenTech technician will work with you to setup and customize the more complex configuration options within the kiosk software. If you have questions throughout the installation process, please reach out to our dedicated support team.



CONTACT INFORMATION

Technical Support (602) 773-1700
support@opentechalliance.com
Fax (602) 324-8658
Office (602) 749-9370



HOURS OF OPERATION

Business Office M-F; 8:00AM to 5:00PM MST
Technical Support M-F; 5:00AM to 5:00PM MST
Sat; 7:00AM to 5:00PM MST

INSOMNIAC® is a registered trademark of OpenTech Alliance, Inc. All configuration and/or installation references are appropriate practices within the U.S. Configuration and installation procedures vary by country and may result in the presence of components that differ in form and/or function from those shown in this document. Unless otherwise noted, all images, illustrations, content and all materials shown in this document are copyrights, trademarks and or intellectual properties, owned, controlled or licensed by OpenTech Alliance, Inc. This document may not be copied in whole or in part without the written consent of OpenTech Alliance, Inc. Copyright © 2022, OpenTech Alliance, Inc. all rights reserved.



TABLE OF CONTENTS

Preface.....	4	Fire Protection.....	6
General Installation.....	4	Heat Gain/Loss.....	6
ADA Compliance.....	4	Protection from Weather.....	6
Power Requirements.....	5	331 Specifications.....	7
Data Cable Requirements.....	6	Product & Install Drawings.....	8
DVR Camera Connection.....	6	Table of Figures.....	11
Plenum Ceiling Consideration...	6		

Looking for a local installer?

We train a network of OpenTech Authorized Dealers throughout the United States. Visit www.opentechalliance.com/dealers to find a local installer near you!

INSTALLATION

Preface

Prior to installing the INSOMNIAC 331, your contractor should review the standards and information contained throughout this document. Please contact OpenTech Alliance Customer Support (via telephone at: 602-749-9370, Option 2, or email at: support@opentechalliance.com) for any upgrades or additional details or questions.

General Installation

- Check with OpenTech Alliance prior to installation for any updates to this installation guide.
- Check all applicable ADA and local codes for accessibility compliance prior to installation.
- The kiosk should be visible once a tenant enters the property from the street.
- The kiosk area should be well lit (to make the user feel safe and comfortable).
- The kiosk should be located on the exterior of the building and visible from the parking area.
- If the property utilizes video recording or surveillance, a camera should be in place to view the kiosk.
- The kiosk should offer the user protection from the elements during use; for example, shade from the hot sun and direct sunlight, and protection from rain and wind, etc.)
- Ideal installation of the kiosk will insure that it is placed just adjacent to the main office entry.
- The kiosk should be located as close to the entry keypad as possible.

ADA Compliance

Accessibility Considerations

The primary issue addressed by The Americans with Disabilities Act (and corresponding local accessibility code requirements), as applied to the kiosk, is provision for proper access to and from the INSOMNIAC 331 kiosk. This includes insuring the presence of an accessible route from public areas (including streets, sidewalks and parking lots).

Installation Specifications

It is suggested that the unit be installed at such a height so as to insure that the microphone is approximately 48" AFF (above finished floor); this will place the kiosk at a height that is accessible to an individual in a wheelchair (for both forward and side approaches). This complies with guidelines set forth by the ADA.

Power Requirements

Wired Power Specifications

The INSOMNIAC kiosk requires 120 VAC, 10 Amp, single-phase, three-wire un-switched power receptacle. Wiring to the receptacle must include a third-wire earth-ground (conduit ground is not acceptable).

Extend a minimum of ¾" metal conduit from service panel to a 4" junction box located no further than 6' from the unit. Boxes can be flush mounted with concealed conduit for new construction, or boxes can be surface mounted with exposed conduit for existing construction.

Although removing power from the kiosk suddenly is not recommended, the system is designed to be resilient against data corruption if power is removed.

Backup Power Supply

An uninterruptible power supply (UPS), also known as an uninterruptible power source, or a battery backup, is a device which maintains a continuous supply of electric power to connected equipment by supplying power from a separate source when utility power is not available. In areas of the country that experience frequent power disruptions ("Tornado Alley," hurricane season, etc.), it is recommended that a UPS be employed in order to minimize the effects of power outages, especially to guard against constant rebooting of the system during periods that the power might be unstable and flickering.

When a power failure occurs, the UPS effectively switches from utility power to its own power source almost instantaneously. The UPS, which is continuously connected to the protected load, draws energy from its reserves, usually stored in lead-acid batteries, converting it to AC power.

In addition to providing protection against complete failure of the utility supply, a UPS also provides protection against all common power problems, and for this reason it is also known as a power or line "conditioner."

Please consult with your electrical contractor for a unit appropriate to your facility.

Data Cable Requirements

Always-On Internet Connectivity

The INSOMNIAC 331 must be connected to the Internet; i.e. an “always-on” Internet connection (such as cable or DSL). The firewall should allow incoming traffic on TCP ports 5721, 80, and 443.

A contractor should run one or two CAT 5 data cables, in grounded conduit, from the location of the computer (or network hub) that runs the management software, to a junction outlet box mounted a few feet from the kiosk. The kiosk comes with a CAT 5 cable that extends 5' from a hole in the back, right-bottom corner of the kiosk (when facing the kiosk from the front).

A second CAT5 cable would be needed to serve an optional “pin hole” IP camera that can connect to the facility’s security monitoring system.

On-Demand/“Dial-Up” Internet Connectivity

The INSOMNIAC 331 does not support an on-demand Internet connection (such as dial-up). However, it can be configured to support connection to a cellular network.

DVR Camera Connection

The INSOMNIAC 331 comes pre-installed with a DVR (Digital Video Recorder) capable camera. If desired, an RG59 BNC cable may be run to the CAT5E junction box. The cable should be terminated with a female BNC connector or have a coupler available.

Plenum Ceiling Consideration

Special considerations must be made if the kiosk will utilize wiring installed through a plenum ceiling. If the area between the ceiling and the roof in a building is used for air return in a ventilation system, fire and building codes normally require that special wire or conduit be used if wire is run through this area.

Fire Protection Consideration

Installation of this kiosk in an existing facility with a new wall enclosure, may impact the sprinkler head cover in this area, and require modification or addition of additional heads.

Heat Gain/Loss Consideration

Installation of this kiosk in small areas with a lack of air circulation should take into consideration the heat gain (build up of heat from operation of the equipment) and design the space accordingly. The operations temperature range is 5 °C to 55 °C.

Protection from Weather

Although the INSOMNIAC kiosk is designed for outdoor use, it should be protected from full weather exposure. A canopy, awning or other covering should be installed above the kiosk to prevent direct rain and/or snow contact.



SPECIFICATIONS

INSOMNIAC 331 Specifications

Weights and Measurements

Shipping Weight	Unit Weight	Kiosk Dimensions	Rear Clearance
+/- 165 lbs	+/- 110 lbs	Height: 60 19/32" Width: 21" Depth: 10 5/16"	INSOMNIAC 331 opens to the front, therefore, no rear access clearance is required and the kiosk may be installed flush to a wall.
Actual shipping and unit weight depends upon shipping materials, options and configuration.			

DRAWINGS

Product & Installation Drawings

Model 331 Wall Mount Location

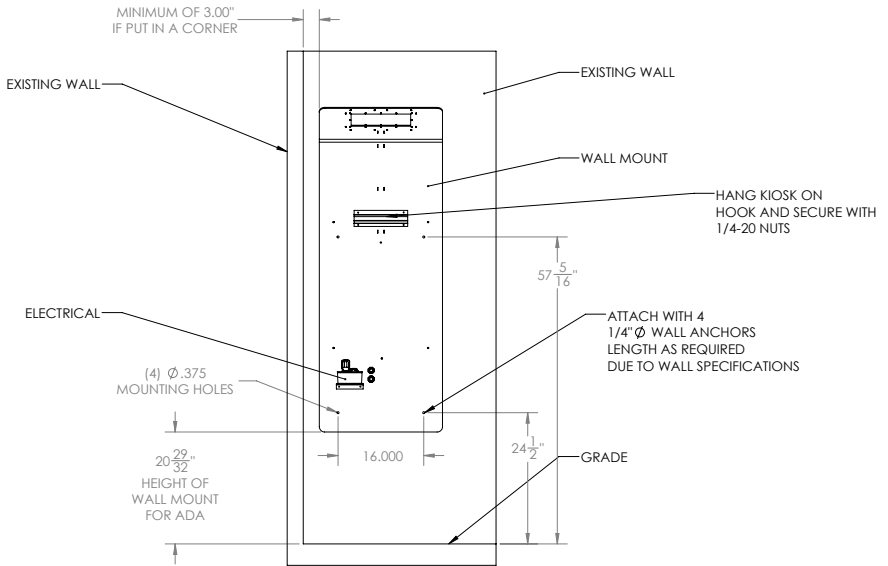

Figure 1: Model 331 Wall Mount Location

Model 331 Right Side View

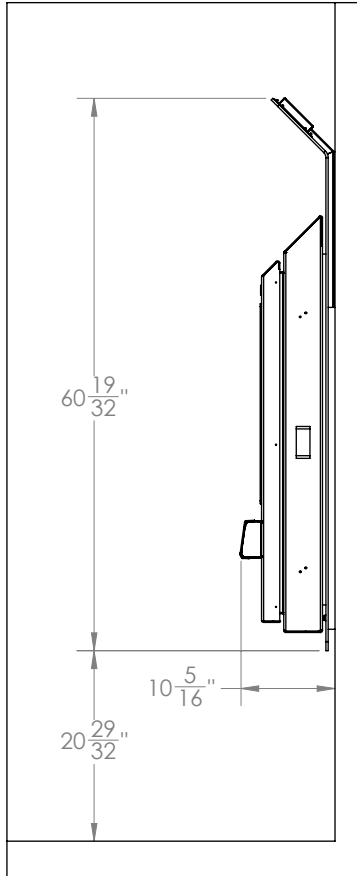
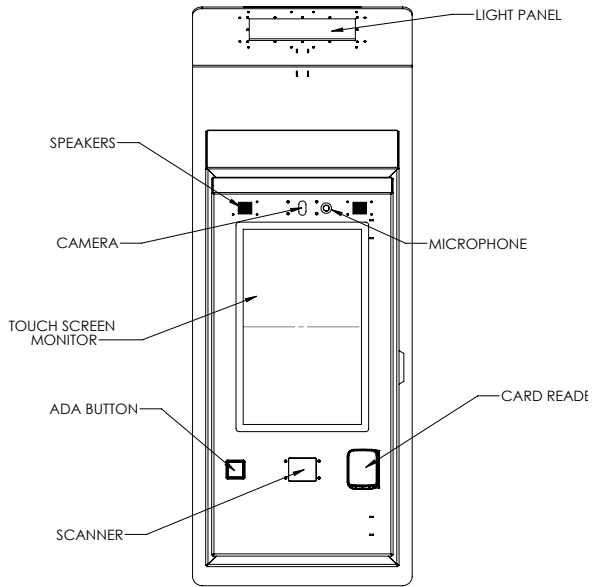

Figure 2: Model 331 Right Side View

Model 331 Front View



PROPRIETARY AND CONFIDENTIAL
 THE INFORMATION CONTAINED IN THIS DRAWING IS THE SOLE PROPERTY OF GENKO METAL WORKS LLC. ANY REPRODUCTION IN PART OR AS A WHOLE WITHOUT THE WRITTEN PERMISSION OF GENKO METAL WORKS LLC IS PROHIBITED.

Figure 3: Model 331 Front View



TABLE OF FIGURES

Figure 1: Model 331 Wall Mount Location.....	8
Figure 2: Model 331 Right Side View.....	9
Figure 3: Model 331 Front View.....	10

The background of the slide is a photograph of a long, brightly lit aisle in a self-storage facility. The aisle is flanked by rows of blue roll-up storage units. The perspective is from the end of the aisle, looking down its length. The lighting is even, and the units are uniform in color and size. The overall tone is professional and organized.

OpenTech Alliance™

 www.OpenTechAlliance.com

 602.749.9370

 support@opentechalliance.com