

INSOMNIAC CIA Individual Unit Alarm

Installation Manual

P/N CIA-A96

Revision 2

Date Code: 1-22-2020

SPECIFICATIONS:

ITEM	DESCRIPTION	FEATURES
1	ENCLOSURE	INDOOR / OUTDOOR, ALUMINUM, POWER COATED
2	COMMUNICATIONS	RS485 OR WIRELESS (900 MHZ)
3	FORM-C RELAY OUTPUTS	1
4	SECURE COMMUNICATIONS	YES
5	TAMPER	YES
6	MAX OPERATING VOLTAGE	24VDC
7	MIN OPERATING VOLTAGE	12VDC
8	MAX INPUT CURRENT	250 mA @ 12 VDC, 125 mA @ 24VDC
9	OPERATING TEMP RANGE	-31 TO 150 DEG. F.
10	HUMIDITY	0-95% NON-CONDENSING
11	INGRESS RATING	OUTDOOR EQUIPMENT

OVERVIEW

This installation guide is for use in with the INSOMNIAC CIA Hardwired Individual Unit Alarm. Please read the entire document before proceeding with the installation. It is recommended that installation be performed by a certified, licensed and component installation company.

The wired alarm systems connects a sensor on each unit's door to the Individual Unit Alarm Board. This allows the INSOMNIAC CIA system to monitor when the door is opened or closed. When a visitor enters the property either via a keypad or the Storage Genie app then the alarm is disarmed. When the visitor exits the property, the alarm is re-armed. If a unit is armed and the door is opened without the visitor entering the property then an alarm will be activated.

This installation document if for use with
CIA-A96-01 CIA Hardwired Unit Alarm – Circuit Board Only.
CIA-A96-02 CIA Hardwired Unit Alarm Enclosure

The INSOMNAIC CIA Hardwired Individual Unit Alarm can be used in new construction or can be used to upgrade older individual unit alarms. For instructions on upgrading older systems, see Section XX of this manual.

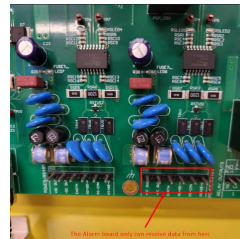

WARNING: Be sure data is pulled only from RS485 channel 2.

WARNING: Do not pull power from RS485 Channels, Mux Boards require external power supplies

WARNING: Incorrect installation of electrical components can result in damage to the electronics as well as personal injury.

WARNING: Cross wiring the AC power with DC power will damage the electronics.

WARNING: Connecting power wires to data wires will damage the electronics.

WARNING: Cross wiring or shorting positive and negative power wires will damage the electronics.

WARNING: Do not run low voltage wires in the same conduit as high voltage wires.

WARNING: The individual Unit Alarm should never be mounted in a rentable unit or other location that is inaccessible for maintenance or servicing.

INSTALLATION

Physical Installation and Mounting

This document contains instruction on installing the INSOMNIC CIA Individual Unit alarm system.

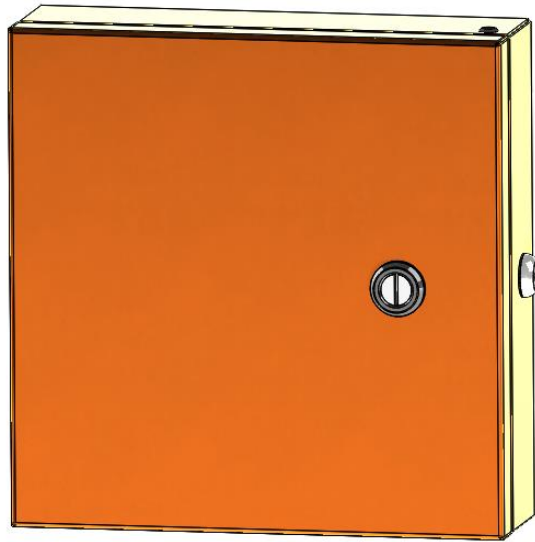

Figure 1

Mount the back plate to the desired location using the 4 holes in the back pane. If the enclosure is being mounted on a wall, before mounting, run a bead of silicone in a square around the back of the enclosure about 1/2 inch from the edge. Also from the inside seal around each screw hole and the wire entry hole with an outdoor silicone sealant after pulling the wires through.

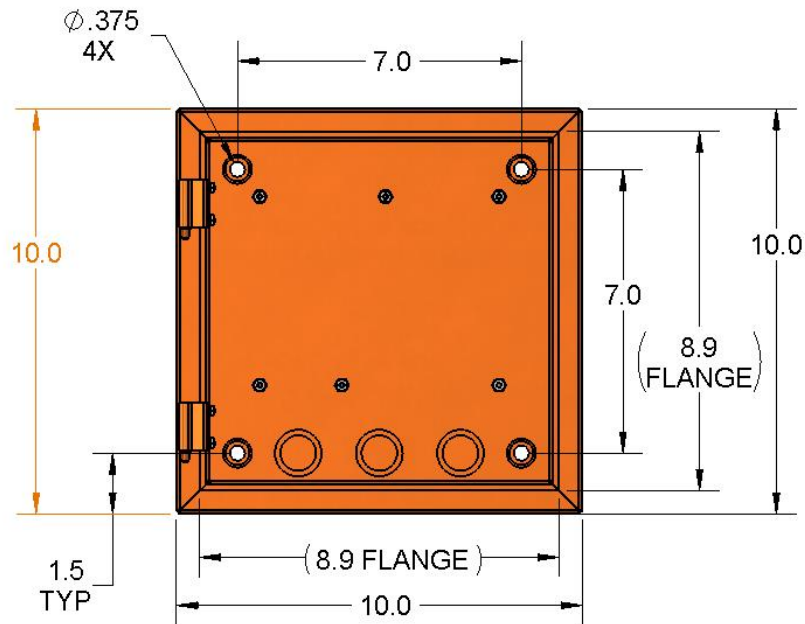

Figure 2

Pull the necessary wires through the wire hole on the back of the housing. Allow ample wire to remain inside the housing. After the wire connections are complete, excess wire can be pushed back into the wall or it can be carefully positioned inside the housing for future maintenance and service.

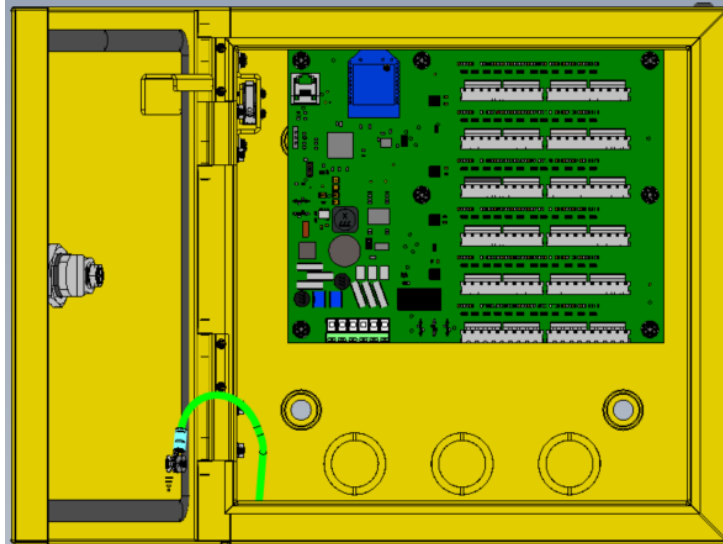

Figure 3

Wiring Connections

Below is a connection diagram for the Unit Alarm Printed Circuit Board (PCB). Note: All installations must conform to local building and electrical codes and shall be in accordance with the Nation Electric Code, ANSI/NFPA 70. When discrepancies exist between local codes and this manual, local code takes precedence. RS485 communication cables entering the enclosure should be insulated and shielded with drain wires connected.

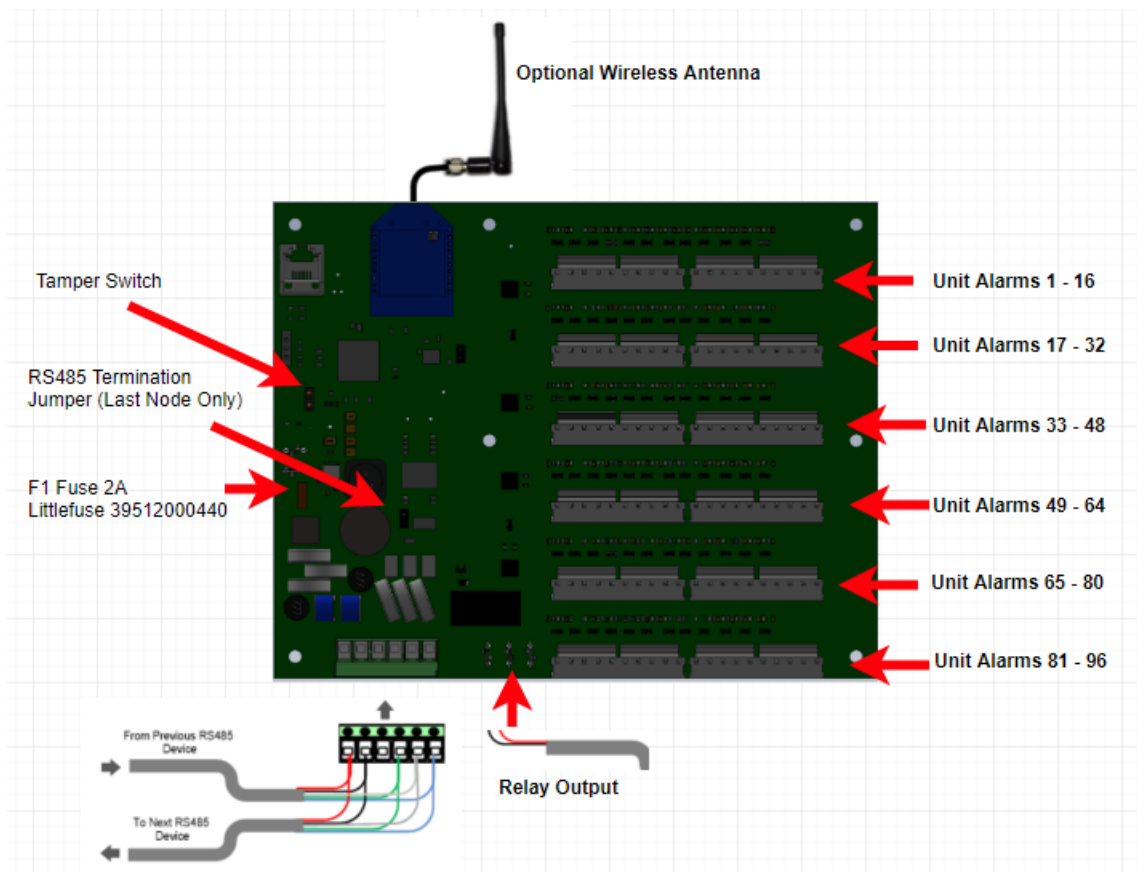

Figure 4

UNIT DOOR ALARM PUNCH DOWN CONNECTORS

There are six punch down connectors on the right side of the circuit board for connecting up to 96 individual unit switches. These connectors are used to connect to the individual unit alarm switches that are installed on the unit doors. Each terminal strip has sixteen inputs and four ground wires. Each alarm switch installed in a unit will be associated with a channel number on the PCB. This channel number will be associated with the unit number in the Control Center. It is recommended that the unit number and channel numbers be documented to facilitate software configuration. See Unit Alarm Connection Worksheet.

Punch Down Connector 1

C h	C h	C h	C h	C h	C h	C h	C h	C h	C h	C h	C h	C h	C h	C h	C h	Gn d	Gn d	Gn d	Gn d
1	2	3	4	5	6	7	8	9	10	11	12	13	14	15	16	Gn d	Gn d	Gn d	Gn d

Punch Down Connector 2

C h	C h	C h	C h	C h	C h	C h	C h	C h	C h	C h	C h	C h	C h	C h	C h	Gn d	Gn d	Gn d	Gn d
17	18	19	20	21	22	23	24	25	26	27	28	29	30	31	32	Gn d	Gn d	Gn d	Gn d

Punch Down Connector 3

C h	C h	C h	C h	C h	C h	C h	C h	C h	C h	C h	C h	C h	C h	C h	C h	Gn d	Gn d	Gn d	Gn d
33	34	35	36	37	38	39	40	41	42	43	44	45	46	47	48	Gn d	Gn d	Gn d	Gn d

Punch Down Connector 4

C h	C h	C h	C h	C h	C h	C h	C h	C h	C h	C h	C h	C h	C h	C h	C h	Gn d	Gn d	Gn d	Gn d
49	50	51	52	53	54	55	56	57	58	59	60	61	62	63	64	Gn d	Gn d	Gn d	Gn d

Punch Down Connector 5

C h	C h	C h	C h	C h	C h	C h	C h	C h	C h	C h	C h	C h	C h	C h	C h	Gn d	Gn d	Gn d	Gn d
65	66	67	68	69	70	71	72	73	74	75	76	77	78	79	80	Gn d	Gn d	Gn d	Gn d

Punch Down Connector 6

C h	C h	C h	C h	C h	C h	C h	C h	C h	C h	C h	C h	C h	C h	C h	C h	Gn d	Gn d	Gn d	Gn d
81	82	83	84	85	86	87	88	89	90	91	92	93	94	95	96	Gn d	Gn d	Gn d	Gn d

The wires for each door switch should be punched down on the terminal strip using the proper tool. Recommend punch down tool is .156 inch IDC T handle. Do not use a telephone punch down tool or screwdriver. The punch down connectors should be removed from the circuit board before the wires are punched down. Place the punch down connectors on a hard surface. Do not punch down wires while the connector is attached to the Unit Alarm Board as this can damage the circuit board.

DOOR SWITCHES

Depending on the door type, there are several different door switches that can be used with the CIA Individual Unit Alarm board. When selecting door switches it is recommended that a wide gap switch is used. Below is a list of selected door switches that are compatible with the system. These switches are provided by the installation company.

Amseco AMS-37L Series magnetic contact can be used for swing or roll up doors. When mounted on roll up doors it is recommended to use a Z-Bracket (4270004). Additional information on Amseco magnetic switches can be found at <https://www.pottersignal.com/product/206/ams-37-series>.

QuickSwitch can be used on both roll up and swing doors if the door latch is made of ferrous metal and is long enough to go all the way through the door switch.

Recessed switches such as the Amesco AMS-21 (<https://www.pottersignal.com/product/246/ams-21-series>) or the Amseco AMS-26 (<https://www.pottersignal.com/product/282/ams-26-series>) can be used for swing doors.

UNIT ALARM (TRUNK) CABLE

For new installations it is recommended that 22 or 24 AWG solid core unshielded cable is used for connection to the individual unit door contacts. It is also recommend that UG crimp connectors are used for connecting the individual switches to the unit alarm (trunk) cable.

The unit alarm (trunk) cable is typically routed from the Individual Unit Alarm Board through the building to each of the units that will be monitored. The wires from the unit switch connect to the unit alarm (trunk) cable above the door. One wire from the switch will connect to a unique individual wire and the other wire will connect to the ground or common wire. The ground or common wire can be shared between multiple switches. For troubleshooting purposes, it is recommended that one ground or common wire is shared with four unit switches. The Unit Alarm Connection Worksheet can be used to document the wiring connection and wire color code.

To connect a switch to the Unit Alarm (Trunk) Cable. Cut lengthwise into the Unit Alarm Cable approximately 3” into the outer installation and expose the individual wires. Exercise caution to not cut or damage the individual wires. Connect the two wires coming from the switch to the Unit Alarm Cable using UG style connectors to the proper wires.

WARNING: It is not recommended that Unit Alarm Cable is run between buildings. A separate Individual Unit Alarm Board should be used for each building.

WARNING: Do not run Unit Alarm (trunk) Cable with unshielded AC power lines or near light fixtures.

WARNING: Unit Alarm (trunk) Cable should not be spliced.

PWR/RS485

Power and RS485 data communication is done with a single connector and should be the last connector to be attached as it may carry active power. We recommend that power and RS485 data communications be via a single 18 AWG, 4-conductor shielded cable. The shield drain wire can be used as the RS-CMN common wire. Do not connect more than two (2) RS485 cables to one PCB. All PCBs shall be connected as an inline chain beginning with the Gateway and ending with the last device. The last device shall have a "termination" jumper installed as shown in Figure 4. All other devices shall have this jumper omitted.

These connectors have 6 pins.

DC + V (12-24VDC) Required.. RED
DC – V (DC Common) Required.. BLK
EARTH Optional
RS485-A Required.
RS-CMN Required.. (Can use Cable SHEILD),
RS-485-B Required

RS485 Limitations

A wired door alarm board can be located up to 4000 feet from the Gateway given proper twisted pair cable with ground wire.

To properly terminate cables into connectors the following instructions apply.

1. Strip back the outer insulation and shield foil from both of the 18 AWG, 4-conductor, shielded cables (coming from the Gateway or previous device in line and going out to the next device in line), being careful not to cut the bare shield wire. Strip ¼ inch of insulation off the end of each of the individual colored conductor wires.
2. Remove the terminal blocks from the door alarm circuit board by sliding them up and off. The terminal blocks may be somewhat difficult to remove, as a tight electrical connection is necessary. If they are tight, rock them slightly back and forth while lifting away from the board.
3. Insert wires into the desired connector. Where 2 wires are tied together, ensure that both wires are seated all the way inside the slot. Use a flathead precision screwdriver to tighten down the terminal screw.
4. Verify that the terminal slot has tightened down on the copper wire and not on the rubber insulation. There should be no copper wire showing outside of the terminal slot. Gently tug the wires to verify that they are tightly held inside the terminal slot. Repeat this process with each of the remaining wire connections as shown in Figure 10.

Warning: Cross-wiring or shorting power wires can damage the circuit board.

Wireless Communications (Optional)

The Individual Unit Alarm can also function without the RS485 wiring. In this case, the XBEE or XBEE Pro wireless module and an RPSMA antenna must be installed on the Gateway and on the Individual Unit Alarm Board. 12-24VDC power is all that is necessary on the PWR/RS485 connector for this option. If the Individual Unit Alarm Board is within wireless range of the Gateway, the Individual Unit Alarm Board will work in same fashion as with RS485 connections. The range depends on the wireless module used. XBEE module range is typically 300ft. XBEE Pro range is typically 1 mile. This equipment option has been tested and found to comply with the limits for a Class B digital device, pursuant to Part 15 of the FCC Rules.

Relay Output

The Individual Unit Alarm has one Normally Closed (NC) , a Common and a Normally Open (NO) connection. Depending on the need, wire to the common and either the NC or NO. On board LED's are provided to show if the relay is activated. Typical sirens and strobes require a normally open contact.

RELAY CONTACT RATINGS:

Item	Rating
Contact Type	Single Ag-Alloy (Cd Free)
Rated Load	5A (NO) / 3A (NC) @ 30VDC
Max Switching Voltage	30VDC
Max Switching Current	5A (NO) / 3A (NC)

Warning: Wiring the relay to the operating device will introduce the operating device control voltage into the Individual Unit Alarm housing. The Individual Unit Alarm is not designed for the presence of high voltage within the enclosure. Relay voltage must not exceed 30 volts.

Earth Ground

To connect the ground wire, run an insulated copper wire (preferably color green) from a grounded water pipe or from a copper rod in the ground to the Individual Unit Alarm and connect it to the green earth ground wire using a wire nut. The enclosures earth wire is connected to the stud in the floor of the enclosure using a screw with a star washer. This installation must meet applicable code as the type of wire, depth of burial, and size of the rod may vary by municipality.

Note: Uninsulated wires (Typically used for earth ground) cannot be located inside the unit's case. Make connections for an uninsulated ground wire outside the enclosure.

Testing / Troubleshooting

Each Unit Alarm input has an LED that will be on when the unit door is closed.

Check the 3 Power LEDs on the PCB. If they are all dark, check / replace the PCB fuse. If any single specific power LED such as the 3.3V or 5V LEDs are dark, replace the PCB.

UNIT ALARM MAINTENANCE

Cleaning:

Yearly: Open the enclosure, inspect and clean the inside of the unit. Remove dirt or dust that has collected on the inside of the housing and the circuit board that could cause problems. Note any signs of water damage or corrosion caused by a leak in the enclosure seals. Replace any worn seals. A small can of compressed air can be used to remove insects and dust from the circuit board.

NOTICES and DISCLAIMERS

Liability Disclaimer: While every effort has been made to ensure the accuracy of the information in this document we assume no liability for any inaccuracies contained herein. We reserve the right to change the information contained herein at any time and without notice.

Individual Unit Alarm Connection Worksheet

Use the worksheet below to document the wire colors used for each unit switch. The Switch and Gnd/Cmn columns should be used to document the wire color that the switch is connected to.

Channel	Unit	Switch	Gnd/Cmn	Channel	Unit	Switch	Gnd/Cm
1				49			
2				50			
3				51			
4				52			
5				53			
6				54			
7				55			
8				56			
9				57			
10				58			
11				59			
12				60			
13				61			
14				62			
15				63			
16				64			
17				65			
18				66			
19				67			
20				68			
21				69			
22				70			
23				71			
24				72			
25				73			
26				74			
27				75			
28				76			
29				77			
30				78			
31				79			
32				80			
33				81			
34				82			
35				83			
36				84			
37				85			
38				86			
39				87			
40				88			
41				89			
42				90			
43				91			
44				92			
45				93			
46				94			
47				95			
48				96			

Upgrading PTI Door Alarms

This section covers upgrading PTI unit alarms. PTI Alarm Boards may have different unit alarm input configurations (16, 32, 48, 64, 80 or 96). The CIA-A96-01 circuit board was designed to allow you to upgrade any of these configurations.

Before upgrading the existing system, it is important to ensure that the individual unit alarms are working properly and the proper units are being reported when the unit door is opened or closed. If the current system is not operational, then it is recommended that these issues are corrected before proceeding.

To speed configuration of the system, the INSOMNIAC CIA has the ability to import the unit/mux/channel configurations from a PTI or StorLogix system. In order for this to be accomplished, it is required to perform an export from the PTI Falcon 2000 or StorLogix software to export the alarm.alm from StorLogix, select Setup, select Assign Input to Units. Select the Advanced tab. Select Export and save a copy of the alarm.alm file. For more information, refer to the StorLogix help file or documentation.

The alarm.alm is a CSV file with the format of Unit#,Mux#,Channel, Status where Status is 0 Alarm Off or 1 Alarm On.

1. Export the Alarm.Alm file from the StorLogix or Falcon 2000 software.
2. Document the existing PTI Door Alarm Mux address and location. The PTI Alarm Mux address can be found by looking at the DIP switches settings on the Mux. This mux number will be used when importing the alarm.alm file to ensure that the mux channel is associated with the proper unit and board.
3. Remove the unit alarm punch down connectors from the old PTI circuit board. Label each connector. The punch down connectors can be connected directly to the CIA A96 Individual unit alarm circuit board.
4. Disconnect and label the alarm relay from the old PTI board if being used.
5. Disconnect the RS-485 power connector from the circuit board. Label each wire DC+, DC-, Data +, Com and Data –
6. Remove the old PTI circuit board from the enclosure. This is typically accomplished by removing four screws that are used to mount the circuit board inside the enclosure.
7. Install the new CIA-A96 circuit board in the existing enclosure using the screws that were used to attach the old PTI circuit board.
8. Reconnect the unit alarm punch down connectors. Ensure that it is connected to the proper channel input.
9. Reconnect the alarm relay if used.

10. Connect RS-485 communication wires Data +, CMN and Data – to the CIA-A96 Circuit Board. Refer to Figure 4. Ensure that the connections are terminated correctly.
11. Connect DC + and DC – to the CIA-A96 Circuit board. **IMPORTANT.** If the device is being powered by a separate 12V power supply, the power wires CAN NOT be connected to the Gateway. The Gateway outputs 24V. Connecting a 12V power will damage the Gateway circuit board.
12. Verify that LEDs turn on off when corresponding unit door is opened or closed.

Upgrading DigiTech UniMux Door Alarms

This section covers upgrading DigiTech individual unit alarm that utilize the UniMux system. Note that DigiTech systems that utilize the matrix contacts CAN NOT be upgraded. The DigiGate UniMux can control different numbers of individual door alarm units (22, 44, 66, 88 or 110). If more than 96 units are being controlled by a UniMux then two CIA-A96 Circuit boards will be required. Note when upgrading DigiTech UniMux alarms the existing enclosure will need to be removed.

Before upgrading the existing system, it is important to ensure that the individual unit alarms are working properly and the proper units are being reported when the unit door is opened or closed. If the current system is not operational, then it is recommended that these issues are corrected before proceeding.

To speed configuration of the system the INSOMNIAC CIA has the ability to import the unit/mux/channel configurations a CSV file.

1. Export the Mux/Slot report. In the DigiGate system select Reports/Misc Report/MuxSlot Report. Export the report. This information will be used to import into the Control Center.
2. Document the existing Door Alarm Mux address and location. The Alarm Mux address can be found by looking at the DIP switches settings on the Mux. This mux number will be used when importing the alarm.alm file to ensure that the mux channel is associated with the proper unit and board.
3. Label and remove each unit alarm wire from the DigiGate UniMux daughter boards. The DigiGate UniMux may contain up to 5 daughter boards addressed A – E. Daughter board A contains slot/channel 1 – 22. Daughter board B contains slot/channel 23 – 44. Daughter board C contains slot/channel 45 – 66. Daughter board D contains slot/channel 67-88. Daughter board E contains slot/channel 89-110. Each daughter board also contains two ground/common wires.
4. Disconnect and label the alarm relay from the old DigiGate board if being used.

5. Disconnect the RS-485 power connector from the circuit board. Label each wire DC+, DC-, Data +, Com and Data –
6. Remove the DigiGate UniMux from the building wall.
7. Install the new CIA-A96 enclosure to the wall. Pulling the existing data communication, relay and unit alarm wires into the new enclosure.
8. Reconnect the unit alarm wires to the punch down connectors
9. Reconnect the alarm relay if used.
10. Connect RS-485 communication wires Data +, CMN and Data – to the CIA-A96 Circuit Board. Refer to Figure 4. Ensure that the connections are terminated correctly.
11. Connect DC + and DC – to the CIA-A96 Circuit board. **IMPORTANT.** If the device is being powered by a separate 12V power supply, the power wires **CAN NOT** be connected to the Gateway. The Gateway outputs 24V. Connecting a 12V power will damage the Gateway circuit board.
12. Verify that LEDs turn on off when corresponding unit door is opened or closed.